

II

(Acts whose publication is not obligatory)

COMMISSION

COMMISSION DECISION

of 29 April 2004

specifying the basic parameters of the ‘Noise’, ‘Freight Wagons’ and ‘Telematic applications for freight’ Technical Specifications for Interoperability referred to in Directive 2001/16/EC

(notified under document number C(2004))

(Text with EEA relevance)

(2004/446/EC)

THE COMMISSION OF THE EUROPEAN COMMUNITIES,

Having regard to the Treaty establishing the European Community,

Having regard to Directive 2001/16/EC of the European Parliament and of the Council of 19 March 2001 on the interoperability of the trans-European conventional rail system ⁽¹⁾, and in particular Article 6(1) and 6(4) thereof,

Whereas:

- (1) In accordance with Article 2(c) of Directive 2001/16/EC, the trans-European conventional rail system is subdivided into structural or functional subsystems . Each of the subsystems is to be covered by a technical specification for interoperability (TSI);

¹ OJ L 110, 20.4.2001, p. 1.

- (2) As a first step, draft TSIs have to be drawn up by the joint representative body under a mandate from the Commission in accordance with the procedure set out in Article 21(2) to the Directive;
- (3) The Committee set up under Article 21 of Directive 2001/16/EC (hereafter ‘the Committee’) has appointed the European Association for Railway Interoperability (hereafter ‘the AEIF’) as the joint representative body;
- (4) The AEIF has been given a mandate to draw up draft TSIs on ‘noise’, ‘freight wagons’ and ‘telematic applications for freight’;
- (5) However, in accordance with Article 6(4) of Directive 2001/16/EC, the first stage in developing the above-mentioned TSIs is to establish the characteristics of their basic parameters to be used by the AEIF; it does not preclude the need to validate and, if necessary, further amend, update or modify these parameters in the corresponding TSI, which shall be adopted in accordance with Article 6(1) of Directive 2001/16/EC;
- (6) A number of specific cases have been requested and are being discussed in the context of the development of the corresponding TSIs. However it is considered more appropriate to include specific cases in the TSIs rather than in this Decision;
- (7) Without prejudice to article 25 of Directive 2001/16/EC, this Decision does not affect either the existing rail system or the development of new projects as long as the corresponding TSIs are not adopted;
- (8) In accordance with the above-mentioned mandate the AEIF has already developed complete draft TSIs for the ‘telematic applications for freight’, ‘noise’ and ‘freight wagons’ subsystems . These TSIs will be adopted once the cost-benefit analysis foreseen by Directive 2001/16/EC are developed and after consultation of users organisations and social partners;
- (9) The definitions and characteristics to be respected for the basic parameters of the ‘noise’, ‘freight wagons’ and ‘telematic applications for freight’ as proposed by the AEIF should be adopted;
- (10) The measures provided for in this Decision are in accordance with the opinion of the Committee set up by Directive 2001/16/EC,

HAS ADOPTED THIS DECISION:

Article 1

The definitions and characteristics to be respected for the basic parameters of the ‘Noise’, ‘Freight Wagons’ and ‘Telematic applications for freight’ TSIs referred to in Directive 2001/16/EC are set out in the Annex to this Decision.

Article 2

This Decision is addressed to the Member States.

Done at Brussels, 29 April 2004.

For the Commission
Loyola DE PALACIO
Vic-President of the Commission

*ANNEX***TABLE OF CONTENTS**

1.	BASIC PARAMETERS RELATED TO THE NOISE TSI.....	5
1.1.	Noise emitted by freight wagons.....	5
1.1.1.	Description of the parameter.....	5
1.1.2.	Characteristics to be respected.....	5
1.2.	Noise emitted by Locomotives, Multiple Units and Coaches.....	6
1.2.1.	Description of the parameter.....	6
1.2.2.	Characteristics to be respected.....	6
2.	BASIC PARAMETERS RELATED TO THE TSI ON FREIGHT WAGONS.....	9
2.1.	Interface (e. g. Coupling) between vehicles, between set of vehicles and between trains.....	9
2.1.1.	Description of the parameter.....	9
2.1.2.	Characteristics to be respected.....	9
2.2.	Safe access and egress for rolling stock.....	10
2.2.1.	Description of the parameter.....	11
2.2.2.	Characteristics to be respected.....	11
2.3.	Functional requirements: Strength of main vehicle structure.....	13
2.3.1.	Description of the parameter.....	13
2.3.2.	Characteristics to be respected.....	13
2.4.	Securing of Freight.....	18
2.4.1.	Description of the parameter.....	18
2.4.2.	Characteristics to be respected.....	18
2.5.	Doors closing and locking.....	18
2.5.1.	Description of the parameter.....	18
2.5.2.	Characteristics to be respected.....	18
2.6.	Labelling of freight wagons.....	19
2.6.1.	Description of the parameter.....	19
2.6.2.	Characteristics to be respected.....	19
2.7.	Special vehicles for the transport of dangerous goods and pressured gases 20	
2.7.1.	Description of the parameter.....	20
2.7.2.	Characteristics to be respected.....	20

2.8.	Kinematic Gauge	21
2.8.1.	Description of the parameter	21
2.8.2.	Characteristics to be respected	22
2.9.	Static axle load, dynamic wheel load and linear load	23
2.9.1.	Description of the parameter	23
2.9.2.	Characteristics to be respected	23
2.10.	Electrical protection of the train	24
2.10.1.	Description of the parameter	24
2.10.2.	Characteristics to be respected	25
2.11.	Vehicle dynamic behaviour (wheel-rail interaction).....	26
2.11.1.	Description of the parameter	26
2.11.2.	Characteristics to be respected	26
2.11.2.1.	General	26
2.11.2.2.	Functional and technical specifications of the subsystem	27
2.12.	Longitudinal compressive Forces.....	28
2.12.1.	Description of the parameter	28
2.12.2.	Characteristics to be respected	28
2.12.2.1.	General	28
2.12.2.2.	Functional and technical specifications of the subsystem	29
2.12.2.3.	Maintenance rules.....	30
2.13.	Braking performance	30
2.13.1.	Description of the parameter	30
2.13.2.	Characteristics to be respected	30
2.13.2.1.	General	30
2.13.2.2.	Functional and Technical Specification of braking performance.....	31
2.14.	Vehicle capability to transmit information between ground and vehicle.....	38
2.14.1.	Description of the parameter	38
2.14.2.	Characteristics to be respected	38
2.14.2.1.	General	38
2.14.2.2.	Functional and technical specification of the subsystem	38
2.14.2.3.	Maintenance rules.....	39
2.15.	Environmental conditions for rolling stock (Range of functioning of components)	40

2.15.1.	Description of the parameter	40
2.15.2.	Characteristics to be respected	40
2.16.	Emergency Exits and Signposting	42
2.16.1.	Description of the parameter	42
2.16.2.	Characteristics to be respected	43
2.17.	Fire Safety	43
2.17.1.	Description of the parameter	43
2.17.2.	Characteristics to be respected	43
3.	BASIC PARAMETERS RELATED TO THE TSI ON TELEMATIC APPLICATIONS FOR FREIGHT	47
3.1.	Consignment Note data	47
3.1.1.	Description of the parameter	47
3.1.2.	Characteristics to be respected	47
3.2.	Path Request	48
3.2.1.	Description of the parameter	48
3.2.2.	Characteristics to be respected	48
3.3.	Train Preparation	49
3.3.1.	Description of the parameter	49
3.3.2.	Characteristics to be respect	49
3.4.	Train Running Forecast	52
3.4.1.	Description of the parameter	52
3.4.2.	Characteristics to be respected	52
3.5.	Service Disruption Information	53
3.5.1.	Description of the parameter	53
3.5.2.	Characteristics to be respected	53
3.6.	Train Location	53
3.6.1.	Description of the parameter	53
3.6.2.	Characteristics to be respected	53
3.7.	Shipment ETI / ETA.....	54
3.7.1.	Description of the parameter	54
3.7.2.	Characteristics to be respected	54
3.8.	Wagon Movement	55
3.8.1.	Description of the parameter	55
3.8.2.	Characteristics to be respected	55

3.9. Interchange Reporting	56
3.9.1. Description of the parameter	56
3.9.2. Characteristics to be respected	56
3.10. Data Exchange for Quality Improvement.....	57
3.10.1. Description of the parameter	57
3.10.2. Characteristics to be respected	57
3.11. Various Reference Files	58
3.11.1. Description of the parameter	58
3.11.2. Characteristics to be respected	58
3.12. Electronic Transmission of Documents.....	59
3.12.1. Description of the parameter	59
3.12.2. Characteristics to be respected	59
3.13. Networking & Communication	60
3.13.1. Description of the parameter	60
3.13.2. Characteristics to be respected	60

1. BASIC PARAMETERS RELATED TO THE NOISE TSI

1.1. Noise emitted by freight wagons

1.1.1. Description of the parameter

Noise emitted by freight wagons subdivides into the pass-by noise and the stationary noise.

The pass-by noise of a freight wagon is highly influenced by the rolling noise (noise of the wheel/rail contact). The parameter set for the characterization of pass-by noise comprises:

- Sound pressure level, according to a defined measuring method,
- Microphone position,
- Speed of the wagon,
- Rail roughness,
- Dynamical and radiation behaviour of the track.

The stationary noise of a freight wagon can only occur, if the wagon is equipped with auxiliary devices like engines, generators, cooling systems. It is mostly applicable for cooling cars. The parameter set for the characterisation of stationary noise comprises:

- Sound pressure level, according to a defined measuring method and microphone position,
- Operating conditions.

1.1.2. Characteristics to be respected

Limits for the Pass-by Noise

The indicator for the pass-by noise is the A-weighted equivalent continuous sound pressure level $L_{pAeq, Tp}$ measured over the pass-by time at a distance of 7.5 m from centreline of track, 1.2 ± 0.2 m above top of rail. The measurements shall be made in accordance to prEN ISO 3095:2001 except that the reference track shall meet the requirements stated in the relevant TSI.

The limiting values $L_{pAeq, Tp}$ for the pass-by noise of freight wagons under these above mentioned conditions are to be determined, based on the performance of K-blocks, while taking necessary safety aspects into account. The AEIF shall take results of measurement campaign as available by 01.02.2004 into account.

The pass-by noise of a train shall be measured at 80 km/h and at maximum speed, but no higher than 200 km/h. The values to be compared with the limits is the maximum of the measured value at 80 km/h and the measured value taken at maximum speed but referred to 80 km/h by the equation

$$L_{pAeq, Tp}(80 \text{ km/h}) = L_{pAeq, Tp}(v) - 30 \cdot \log (v/80 \text{ km/h}).$$

Limits for the Stationary noise

Sound pressure of the stationary noise has to be described by the A-weighted equivalent continuous sound pressure level $L_{pAeq,T}$, according to prEN ISO 3095:2001, chapter 7.5. The limiting values $L_{pAeq,T}$ for the stationary noise of freight wagons in a distance of 7.5 m from centreline of track are given in **Table 1**.

Wagons	$L_{pAeq,T}$
All freight wagons	≤ 65 dB(A)

Table 1: Limiting values $L_{pAeq,T}$ for the stationary noise of freight wagons

The sound pressure level of the stationary noise is the energetic mean of all measuring values taken at the measuring points according to prEN ISO 3095:2001 Annex A, Figure A.1..

1.2. Noise emitted by Locomotives, Multiple Units and Coaches

1.2.1. Description of the parameter

Noise emitted by locomotives, multiple units and coaches subdivides into the stationary noise, the starting noise, and the pass-by noise. The stationary noise is highly influenced by the auxiliaries, namely the cooling systems, the air conditioning and the compressor.

The starting noise is also dominated by the auxiliaries in addition to the sound of the wheel/rail contact, especially as a function of wheel slip velocity, by the traction components (motor, gear, traction converter and Diesel engines).

The pass-by noise is highly influenced by the rolling noise, linked to the wheel/rail interaction, as function of speed of the vehicle. The rolling noise itself is caused by the roughness and dynamical behaviour of the track. In the case of lower speeds, the noises of auxiliaries and traction units are also involved. The emitted level of noise is characterised by:

- Sound pressure level, according to a measuring method,
- Microphone position.

Multiple units are fixed trainsets either with distributed power or with one or more special dedicated power cars and coaches. Multiple units with electric traction are abbreviated as “EMU’s”, with Diesel traction as “DMU’s”. In this document, the wording “Diesel” or “Diesel engine” comprises all kinds of thermal engines which are used for traction. Fixed formation trains that consist of two locomotives and coaches cannot be considered as multiple units if the locomotives can operate in different train configurations.

1.2.2. Characteristics to be respected

The limits for the stationary noise are defined in a distance of 7.5 m from the centreline of track, 1.2 m and 3.5 m above the upper surface of the rails. The measuring conditions are defined by the standard pr EN ISO 3095:2001 with the deviations defined in the relevant TSI. The indicator for the sound pressure level is $L_{pAeq,T}$. The limiting values for

the noise emission of the vehicles under these above mentioned conditions are given in **Table 2**.

Vehicles	$L_{pAeq,T}$
Electric locomotives	75
Diesel locomotives	75
EMU's	68
DMU's	73
Passenger coaches	65

Table 2: Limiting values $L_{pAeq,T}$ for the stationary noise of E-, D-locomotives, EMU's, DMU's and passenger coaches

Limits for the Starting Noise

The limits for the starting noise are defined in a distance of 7.5 m from the centreline of track, 1.2 m and 3.5 m above the upper surface of the rails. The measuring conditions are defined by the standard pr EN ISO 3095:2001 with the deviations defined in the relevant TSI. The indicator for the sound pressure level is L_{pAFmax} . The limiting values for the starting noise of the vehicles under these above mentioned conditions are given in **Table 3**.

Vehicle	L_{pAFmax}
Electric locomotives	82
Diesel locomotives	86
EMU's	82
DMU's	83

Table 3: Limiting values L_{pAFmax} for the starting noise of E-, D-locomotives, EMU's, DMU's

Limits for the Pass-by Noise

The limits for the pass-by noise are defined in a distance of 7.5 m from the centreline of the reference track, 1.2 m or 3.5 m above the upper surface of the rails for a vehicle speed of 80 km/h. The indicator for the sound pressure level is $L_{pAeq,Tp}$.

The measurements shall be done in accordance with prEN ISO 3095:2001 except that the reference track shall meet the requirements stated in the relevant TSI.

The pass-by noise of a train shall be measured at 80 km/h and at maximum speed, but no higher than 200 km/h. Other speeds mentioned in the ISO EN 3095 shall not be considered. The value to be compared with the limits (see **Table 4**) is the maximum of the measured value at 80 km/h and the measured value taken at maximum speed but referred to 80 km/h by the equation.

$$L_{pAeq,Tp}(80 \text{ km/h}) = L_{pAeq,Tp}(v) - 30 \cdot \log(v/80 \text{ km/h}).$$

The limiting values for the noise emission of E-, D-locomotives, EMU's, DMU's and passenger coaches under these above mentioned conditions are given in **Table 4**.

Vehicle	$L_{pAeq,Tp} @ 7,5 \text{ m}$
Electric locomotives	85
Diesel locomotives	85 (to be confirmed by test)
EMU's	81
DMU's	82

Passenger coaches	80
-------------------	----

Table 4: Limiting values $L_{pAeq,Tp}$ for the pass-by noise of E-, D-locomotives, EMU's, DMU's and passenger coaches

2. BASIC PARAMETERS RELATED TO THE TSI ON FREIGHT WAGONS

2.1. Interface (e. g. Coupling) between vehicles, between sets of vehicles and between trains

2.1.1. Description of the parameter

A device used for connecting one railway vehicle (set of vehicles, train) to another.

Within interoperable trainsets any individual coupling system as required can be used. These trainsets must have the interoperable emergency coupling available for use at the ends.

Interface requirements between interoperable vehicles/trainsets are only to be defined for mechanical, electrical and pneumatic couplings in normal and emergency conditions. Gangways for interfacing with passenger vehicles are included where appropriate.

2.1.2. Characteristics to be respected

General

Wagons shall have resilient buffing and draw gear at both ends.

Rakes of wagons which are never split up when in service are considered as a single wagon for the application of this requirement. The interfaces between these wagons shall incorporate a resilient coupling system, which can withstand the forces due to the intended operational conditions.

Trains which are never split up in service are considered as a single wagon for the application of this requirement. If they do not have a standard screw coupler and buffers they shall have the facility to fit an emergency coupler at both ends. The connections between the individual wagons shall satisfy the above requirements for rakes of wagons.

Buffers

When buffers are fitted, two identical buffers shall be fitted at a vehicle end. These buffers shall be of a compressible type.

The height of the centre line of the buffing gear shall be between 940 mm and 1065 mm above rail level in all conditions of loading.

The standard distance between buffer centrelines shall be nominally 1750 mm symmetrically about the centreline of the freight wagon.

Buffers shall have a minimum stroke of $105 \text{ mm} \begin{smallmatrix} 0 \\ -5 \end{smallmatrix}$ mm and an energy absorption capability of at least 30 kJ.

The buffer heads shall be convex and the radius of curvature of their spherical working surface equal to $2750 \text{ mm} \pm 50 \text{ mm}$.

Wagons fitted with buffers with a stroke in excess of 105 mm shall always have four identical buffers (elastic systems, stroke) exhibiting the same design characteristics.

If interchangeability of the buffers is required the following free space on the headstock shall be provided for the supporting plate. The buffer shall be fixed to the wagon headstock by means of four M24 Ø locked fasteners (e.g. self locking nut etc.) of a quality class which provides a yield strength of at least 640 N/mm².

Buffers shall have an identification mark. The identification mark shall contain at least the buffer stroke in “mm” and a value for the energy storage capacity of the buffer.

Draw Gear

The standard draw gear between vehicles shall be non-continuous and comprises a screw coupling permanently attached to the hook, a draw hook and a draw bar with a spring system.

The height of the centre line of the draw hook shall be between 950 mm and 1045 mm above rail level in all conditions of loading.

The draw hook and the draw bar shall withstand a force of 1000 kN without breaking.

The screw coupler shall withstand a force of 850 kN without breaking. The breaking strength of the screw coupler shall be lower than the breaking strength of other parts of the draw gear.

The maximum weight of the screw coupler shall not exceed 36 kg.

The length of the screw coupler measured from the point of engagement of the coupler bow to centre of the coupler bolt and draw-hook shall conform to:

- 986 mm ⁺¹⁰_{-.5} mm with completely screwed-out coupler
- 750 mm ± 10 mm with completely screwed-in coupler.

Each wagon end shall have a facility for supporting a coupling when it is not in use. No part of the coupler assembly shall reach below 140 mm above top of rail when its centreline is at lowest permitted position.

Interaction of draw- and buffing-gear

The relative location of the buffers and draw gears shall be adjusted to each other so as to enable the safe transit of curves in the track with a radius of 150 m. For two wagons, which are coupled on straight track with touching buffers, the pre-load force between these components on a 150 m curve in the track shall not exceed 250 kN.

The distance between the front edge of a draw-hook opening and the front side of the fully extended buffers shall be to 355 mm ⁺⁴⁵_{-.20} mm in new condition.

2.2. Safe access and egress for rolling stock

2.2.1. Description of the parameter

For freight wagons: Shunting, operation, access and egress for railway staff or loading personal. Only for tank wagons: access to the tank plate.

This parameter includes dimensions, position and height of steps and hand grips, as well as non slip-design for crew, stepping to ground and door strength and resistance to forces.

2.2.2. Characteristics to be respected

Vehicles shall be designed so that staff are not exposed to undue risk during coupling and uncoupling. If screw couplers and side buffers are used, the required spaces shown in fig. 1 here below shall be free of fixed parts. Connecting cables and flexible hoses may be inside this space. There shall be no devices under the buffers that hinder the access to the space.

Fig. 1 Bern Rectangle

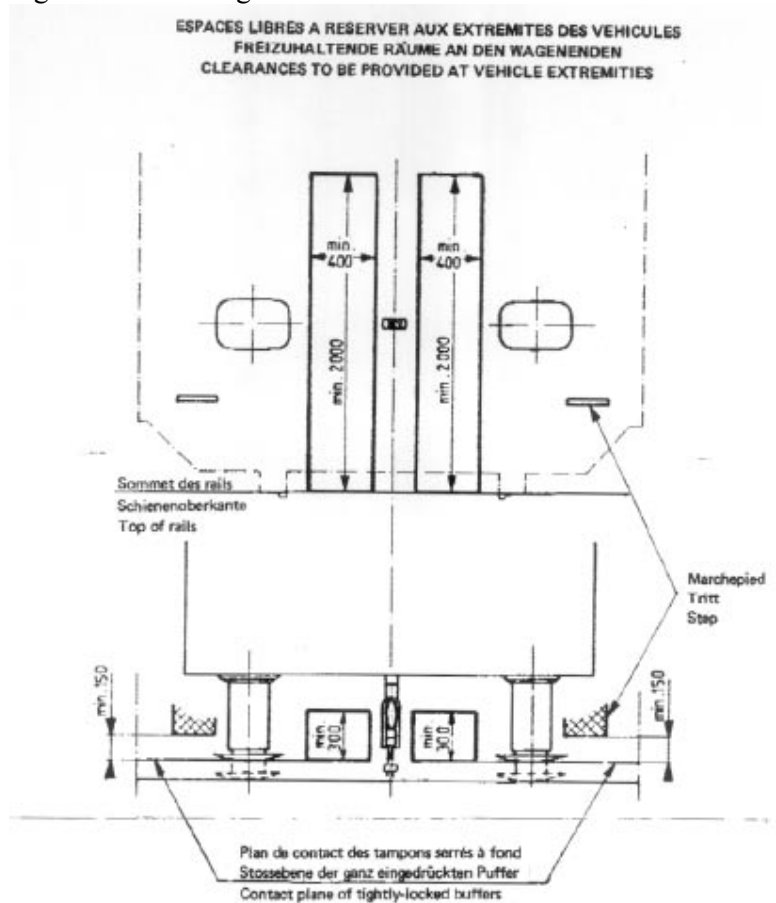

If a combined automatic and screw coupler is fitted the auto coupler head can infringe the Bern rectangle on the left hand side (as viewed in fig. 1) when it is stowed and the screw coupler is in use.

There shall be a handrail under each buffer. The handrails shall withstand the loads, which are applied by the shunters while accessing the space between the buffers.

All fixed pieces situated at the extremities of vehicles outside the clearances defined in Figure 1 and higher than the bottom edge of the buffer heads must be at a distance of at least 40 mm from the frontal plane of the fully-compressed buffers.

Except for wagons used only in fixed formation trains, there shall be at least one step and one handrail for shunters at each side of the vehicle. There shall be sufficient space above and around the steps so that the safety of the shunter is ensured. Steps and handrails shall be designed to withstand the loads that are applied by the shunter. Steps shall be at least 150 mm from a vertical plane at the end of the fully compressed buffers. Steps and areas, which provide access for operation, loading and unloading, shall be slip resistant.

At each end of a wagon that can form the end of a train, there shall be devices for mounting a taillight. Steps and handrails shall be provided where necessary to enable easy access.

The handrails and footsteps shall be inspected at normal maintenance periods and remedial action taken if signs of significant damage, cracking or corrosion are found.

2.3. Functional requirements: Strength of main vehicle structure

2.3.1. Description of the parameter

Future design targets should be to increase payload of freight wagons by decreasing the tare weight.

The present Basic parameter:

- Defines the minimum structural requirements for the main load carrying (primary) structure of the vehicles vs. exceptional functional loads and service loads. The loads must include those experienced due to the vehicle mass, to the payload, to the motion along the track, to acceleration and braking and those exerted on the structure by the equipment attached to it (see also Lifting and Jacking.);
- Specifies limiting stiffness criteria (torsional stiffness);
- Gives permissible stresses for materials in terms of acceptable data sources (static and fatigue) and methods of assessment;
- Specifies acceptable methods of validation.

2.3.2. Characteristics to be respected

General

The structural design of wagons shall be carried out in accordance with the requirements of Section 3 of EN12663 and the structure shall meet the criteria defined in Clauses 3.4 to 3.6 of this standard.

In addition to the criteria already identified, it is permissible to take the material elongation at failure into account in the selection of the safety factor defined in clause 3.4.2. The Guidance Notes indicate an acceptable approach.

When performing fatigue life assessments it is important to ensure that the load cases are representative of the intended application and expressed in a manner consistent with the adopted design code. Any guidelines on the interpretation of the selected design code should be followed.

The permissible stresses for the materials used in the construction of wagons shall be determined as specified in Section 5 of EN12663.

The wagon structure shall be inspected at normal maintenance periods and remedial action taken if signs of significant damage, cracking or corrosion are found.

This section defines the minimum structural requirements for the main load carrying (primary) structure of the wagons and the interfaces with equipment and payload.

These requirements cover:

- Exceptional loads:
 - Longitudinal design loads
 - Maximum vertical load

- Load combinations
- Lifting and jacking
- Equipment attachment (including body/bogie)
- Other exceptional loads
- Service (fatigue) loads:
 - Sources of load input
 - Payload spectrum
 - Track induced loading
 - Traction and braking
 - Aerodynamic loading
 - Fatigue loads at interfaces
 - Body/bogie connection
 - Equipment attachment
 - Coupler loads
 - Combinations of fatigue loads
- Stiffness of the main vehicle structure
 - Deflection
 - Mode of vibration
 - Torsional stiffness
 - Equipment
- Securing of freight

Measures shall be taken to ensure that the load or parts of the load do not leave the freight wagon during operation.

Exceptional Loads

Longitudinal Design Loads

Different values will apply for different kinds of freight wagons as identified in EN12663 namely:

F-I Wagons that may be shunted without restriction;

F-II Wagons excluded from hump or loose shunting.

The basic structural design requirements assume that wagons in the above categories are fitted with buffers and couplers appropriate to the operations.

The structure shall conform to the requirements of Clause 3.4 of EN12663 when subject to all exceptional load cases.

The wagon bodies shall meet the longitudinal strength requirements as specified in tables 1, 2, 3, and 4 of EN12663 as appropriate, where the load paths exist.

NOTE 1 A force applied to one end of the wagon body shall be reacted at the corresponding position at the opposite end.

NOTE 2 Forces shall be applied horizontally to the mounting structure, divided equally on the axis of each side buffer location or on the axis of the coupler.

Maximum Vertical Load

The wagon body shall meet the requirements of table 8 of EN12663.

The wagon body shall also be designed to carry the maximum load it may experience due the method of loading and unloading. The load case may be defined in terms of accelerations applied to the mass being added and to the mass of the body plus any existing payload. The design cases shall represent the most unfavourable cases that the operator wishes to consider associated with the use of the wagon (including foreseeable abuse).

NOTE 1 If the method of analysis employs a permissible stress that is reduced below the yield or proof stress of the material by a safety factor (as indicated in note a) of table 8 of EN12663, the load factors may be reduced by the same ratio.

NOTE 2 Loads may be distributed uniformly over the full load-carrying surface, over a limited area or at discrete positions. The design case(s) shall be based on the most demanding applications.

NOTE 3 If it is intended that wheeled vehicles (including fork-lift trucks etc.) will operate over the floor of the wagon then the design shall accommodate the maximum local pressure loading associated with such operations.

Load combinations

The structure shall also conform to the requirements of Clause 3.4 of EN12663 when subject to the most adverse load combinations as specified in Clause 4.4 of EN12663.

Lifting and Jacking

The wagon body shall incorporate lifting points by which the whole wagon can be safely lifted or jacked. It shall also be possible to lift one end of the wagon (including its running gear) with the other end resting on the remaining running gear.

The load cases specified in Clause 4.3.2 of EN12663 shall apply for lifting and jacking under workshop and servicing operations.

For lifting cases associated only with rescue following derailment or other abnormal incident, where some permanent deformation of the structure is acceptable, it is permissible to reduce the load factor in Tables 9 and 10 from 1.1 to 1.0.

The lifting shall occur via designated lifting points. The location of the lifting points shall be defined by the customer's operational requirements.

Equipment Attachment (Including body/bogie)

The attachments of equipment shall be designed to carry the loads specified in tables 12, 13 and 14 of Section 4.5 of EN12663.

Other Exceptional Loads

The load requirements for structural parts of the wagon body, such as side and end wall structures, doors, stanchions and load restraint systems shall be designed to carry the maximum loads they will experience in performing their intended

function. The load cases shall be determined using the principles for structural design given in EN12663.

For new types of wagon the designer shall determine appropriate load cases to meet the specific requirements using the principles given in EN12663.

Service (fatigue) Loads

Sources of load input

All sources of cyclic loading that can cause fatigue damage shall be identified. In accordance with Clause 4.6 of EN12663, the following specific inputs shall be considered and the way in which they are represented and combined shall be consistent with the intended use of the freight wagon and the design code to be used.

Payload Spectrum

Changes in payload are likely to cause significant fatigue load cycles. Where the payload changes significantly, the time spent at each load level shall be determined. Load/unload cycles should also be determined from the operator's specified duty and represented in a suitable manner for analysis purposes. Where applicable, account shall be taken of changes to the distribution of the payload and to the local pressure loads due to wheeled vehicles moving over the floor of the wagon.

Track induced loading

Induced load cycles resulting from vertical, lateral and twist irregularities of the track shall be taken into account. These load cycles may be determined from:

- a) dynamic modelling;
- b) measured data;
- c) empirical data.

Fatigue design should be based on load case data and assessment methods proven in the application where these exist. Tables 15 and 16 of EN12663 give empirical data, in the form of wagon body accelerations consistent with normal European operations suitable for an endurance limit approach to fatigue design when normal established data is available.

Traction and braking

Load cycles due to traction and braking shall reflect the number of start-stops (including unscheduled ones) associated with the intended mode of operation.

Aerodynamic loading

Significant aerodynamic load input may arise due to:

- a) trains passing at speed;
- b) tunnel operation;
- c) cross winds.

If such loading generates significant cyclic stresses in the structure it shall be included in the fatigue assessment.

Fatigue loads at interfaces

The dynamic load used in design shall be in a range of $\pm 30\%$ of the vertical static load.

If this assumption is not chosen, then the following method shall be followed.

The main fatigue loads at the body-bogie connection are due to:

- a) load/unload cycles;
- b) track input;
- c) traction and braking.

The interface shall be designed to carry the cyclic loads due these inputs.

Equipment attachments shall withstand the cyclic loads due to the motion of the wagon and any loads induced by the operation of the equipment. The accelerations may be determined as described above. For normal European operations, empirically derived accelerations for items of equipment that follow the motion of the wagon structure are given in tables 17, 18 and 19 of EN12663 and can be used where no more appropriate data is available.

Cyclic loads in coupling components shall be taken into account if the experience of the operator or designer indicates they are significant.

Combinations of Fatigue Loads

Where the fatigue load cases act in combination, they shall be taken into account in a manner consistent with the characteristics of the loads and the form of design analysis and fatigue design code being employed.

Buffing load

Freight wagons intended to go over a hump:

Freight wagons shall withstand impacting with a stationary 80 t gross laden weight freight wagon at a speed of 12 km/h without permanent deformation.

Freight wagons not intended to go over a hump:

Freight wagons shall withstand impacting with a stationary 80 t gross laden weight freight wagon at a speed of 7 km/h without permanent deformation.

Stiffness of the main vehicle structure

Deflections

Deflections under the loads or load combinations shall not be such as to cause the wagon or its payload to exceed the permitted operational envelope. Deflections shall also not impair the functionality of the wagon as a whole or that of any installed components or systems.

Modes of vibration

The natural modes of vibration of the wagon body, in all loading conditions including tare, shall be separated sufficiently, or otherwise de-coupled from the suspension frequencies, so as to avoid the occurrence of undesirable responses at all operating speeds.

Torsional stiffness

The torsional stiffness of the wagon body shall be consistent with the suspension characteristics such that the derailment criteria are achieved in all loading conditions including tare.

Equipment

The natural modes of vibration of equipment, on its mountings, shall be separated sufficiently, or otherwise de-coupled from the wagon body or suspension frequencies, so as to avoid the occurrence of undesirable responses at all operating speeds.

As an interface with the *Rolling Stock – Freight Wagons* sub-system, the sub-system *Infrastructure* has to comply with these characteristics.

2.4. Securing of Freight

2.4.1. Description of the parameter

Freight transport has to be secured in a safe way. The integrity of the securing system has to be demonstrated.

2.4.2. Characteristics to be respected

Measures shall be taken to ensure that the load or parts of the load do not leave the freight wagon during operation.

2.5. Doors closing and locking

2.5.1. Description of the parameter

The scope of the basic parameter is the prevention of freight or gauge-infringement while the train is moving. It includes equipment doors and hatches as well as measures to prevent unintended opening.

2.5.2. Characteristics to be respected

Doors and hatches of freight vehicles shall be closed and locked while the vehicles are in a moving train (unless this is part of the procedure for discharging the payload). For this, locking devices shall be used which indicate their status (open/closed). The locking devices shall be secured against unintentional opening.

Closing and locking systems shall be designed so that the operating staff are not placed at undue risk.

The closing and locking devices shall be designed to withstand the loads which are caused by the payload under normal, regular conditions and when the payload has been displaced in a foreseeable manner.

The closing and locking devices shall be designed to withstand the loads that occur while the vehicles are passing other trains under all conditions, including when in tunnels.

The forces, which are needed to actuate the closing and locking devices, shall be of a magnitude that can be applied by an operator without additional tools. Exceptions are

allowed when additional tools are specifically made available or when motor driven systems are used.

The closing and locking systems shall be inspected at normal maintenance periods and remedial action taken if signs of damage or malfunction are found.

2.6. Labelling of freight wagons

2.6.1. Description of the parameter

The basic parameter specifies the labelling of equipment and facilities on vehicles operated by railway staff. Labelling is required in order to ensure safe operation, e.g. by indicating certain design features of the vehicle that must be known by railway staff in the course of their duties, as for example:

- Vehicle number
- Braking performance and brake system cocks
- Drain cocks
- Electrical isolation switches
- Safety notices relevant to wagon type
- Vehicle tare weight and load capacity
- Lifting/jacking points
- Geometrical features
- Pneumatic and electrical pipes
- Power supply systems
- High voltage lines
- Possibility of ferry boat fixation
- Min possible curve radius
- Possibility of running on humps.

2.6.2. Characteristics to be respected

Markings are required on wagons to:

- Identify each individual wagon by its unique number, as specified in the Traffic Operations and Management TSI, and recorded in the Register;
- Provide information required to produce train consists, including brake mass, length over buffers, tare weight, speed versus load table for different line categories;
- Identify operational restrictions to staff, including geographical limitations, and shunting restrictions;
- Provide pertinent safety information for staff operating wagons or attending in an emergency, including overhead live wire and electrical equipment warning signs, lift / jacking points, vehicle specific safety instructions.

These markings will be listed in the relevant TSI. The markings shall be located as high as practicable on the wagon structure up to a height of 1600mm above rail level. The markings of wagons which do not have vertical sides shall be affixed on special panels. Markings may be achieved by painting or decals.

When decals are used they shall meet requirements relating to:

- Adhesive strength
 - Environmental friendliness
 - Water resistant, UV resistant, abrasive resistant, chemical resistant.
- The requirements for Dangerous Goods Markings are covered by directive 96/49/EC with its valid Annex RID and are not, therefore, included in this basic parameter.

When changes to a wagon occur that require changes to the markings, such changes shall be consistent with changes to the data recorded in the Rolling Stock Register.

Markings shall be cleaned / replaced when required to ensure that they remain legible.

2.7. Special vehicles for the transport of dangerous goods and pressured gases

2.7.1. Description of the parameter

The tanks or other parts of freight wagons for the transport of dangerous goods shall be designed to enable a safe transport. The basic parameter gives specifications on special vehicles for the transport of dangerous goods and pressured gases. For example, the following features shall be addressed:

- RID
- TPED

2.7.2. Characteristics to be respected

General

Wagons carrying dangerous goods shall meet the requirements of this TSI and in addition the requirements of RID.

The RID which is an Annex of Council Directive 96/49/EC ensures a very high safety level. Further developments in this legal area are led by an international working group (RID-Committee) of representatives from the governments which are members of the COTIF.

Legislation applicable to rolling stock for the transport of dangerous goods

Rolling Stock	Council Directive 96/49/EC and its Annex in their valid version
Marking and Labelling	Council Directive 96/49/EC and its Annex in their valid version
Buffers	Council Directive 96/49/EC and its Annex in their valid version
Spark protection	Council Directive 96/49/EC and its Annex in their valid version

Use of wagons for the transport of Dangerous Goods in long tunnels	Under examination by working groups mandated by the European Commission (AEIF and RID)
--	---

Additional legislation applicable to tanks

Tank	Council Directive 1999/36/EC on transportable pressure equipment (TPED) in its valid version
Tank testing, inspection and marking	EN 12972 Tanks for transport of dangerous goods-testing, inspection and marking of metallic tanks from April 2001

Maintenance rules

The maintenance of tank/freight wagons shall be compliant with the following standard and the Council Directive:

• Testing and inspection	EN 12972 Tanks for transport of dangerous goods-testing, inspection and marking of metallic tanks from April 2001
• Maintenance of Tank and its equipment	Council Directive 96/49/EC and its Annex in their valid version
• Mutual agreements on Tank-inspectors	Council Directive 96/49/EC and its Annex in their valid version

Council Directive 96/49/EC and its Annex RID shall also be taken into account.

2.8. Kinematic Gauge

2.8.1. Description of the parameter

The gauge is a concept designed to define external sizes so that rolling stock can be operated without encountering any obstacle associated with fixed installations (tunnel walls, catenary or signal posts, bridge parapets, platforms, etc.). The gauge is thus two-fold: the structure gauge which defines the minimum size of the infrastructure, and the gauge of the rolling stock which defines its maximum size.

Rolling stock gauge is defined in terms of the envelope within which the rolling stock is contained when operating. The gauge of rolling stock travelling on a given line section must always be smaller, by an appropriate safety margin, than the minimum structure gauge of the line in question. The future Infrastructure TSI will indicate the gauge requirements for new, upgraded, renewed and existing lines.

The basic parameter defines maximum allowable kinematic envelope which a vehicle may use and specify the principles to be used for determining the kinematic envelope.

2.8.2. Characteristics to be respected

This section defines the maximum outside dimensions of wagons to ensure that they remain within the infrastructure gauge. To achieve this, the maximum possible movement of the wagon is considered. This is called the kinematic envelope.

The kinematic envelope of the rolling stock is defined by means of a reference profile and its associated rules. It is obtained by applying the rules giving reductions in relation to the reference profile, which the various parts of the rolling stock shall meet.

These reductions depend on:

- the geometric characteristics of the rolling stock in question,
- the position of the cross-section in relation to the bogie pivot or to the axles,
- the height of the point considered in relation to the running surface,
- constructional tolerances,
- the maximum wear allowance,
- the elastic characteristics of the suspension.

The study of the maximum construction gauge takes into account both the lateral and vertical movements of the rolling stock, drawn up on the basis of the geometrical and suspension characteristics of the vehicle under various loading conditions.

The construction gauge of rolling stock travelling on a given section of line must always be smaller, by an appropriate safety margin, than the minimum structure gauge of the line in question.

A rolling stock gauge comprises two fundamental elements: a reference profile and the rules for that profile. It allows determination of the maximum dimensions of rolling stock and the position of fixed structures on the line.

In order that a rolling stock gauge is applicable, the following three parts of that gauge shall be specified:

- the reference profile;
- the rules for determining the maximum construction gauge for the wagons;
- the rules for determining the clearances to structures and the track spacing.

The relevant TSI shall specify the reference profile and the rules for the maximum construction gauge for the wagons.

The associated rules for determining the clearances for installation of structures are covered in the Infrastructure TSI.

All equipment and parts of wagons that give rise to transverse and vertical displacements shall be checked at appropriate maintenance intervals.

In order to keep the wagon inside the kinematic gauge, the maintenance plan shall include provision for inspection of the following items:

- wheel profile and wear,
- bogie frame,
- springs,
- side barriers,
- body structure,
- constructional clearances,
- maximum wear allowance,
- elastic characteristics of the suspension,
- axle guide wear,
- elements that affect the vehicle flexibility coefficient,
- elements that affect the roll centre.

As an interface with the *Rolling Stock – Freight Wagons* sub-system, the sub-system *Infrastructure* has to comply with these characteristics.

2.9. Static axle load, dynamic wheel load and linear load

2.9.1. Description of the parameter

When a train circulates on a rail track, the rail undergoes load strain and this must be tolerated. These loads are both static and dynamic and are transferred to the track through the running gear. The track and rolling stock must be designed in such a way as to ensure that these loads remain within the line safety limits.

The strength of the track to support vehicles is a function of the design and maintenance of the track-bed and structures. The axle load and axle spacing (wheelbase) of the vehicles define the vertical quasi-static load input to the track.

The axle load of the rolling stock shall not exceed the lowest axle load limit of the lines (at the allowed maximum speed of the rolling stock) on which it is intended to run. The future Infrastructure TSI will indicate the requirements of the lines of the trans-European conventional rail network.

2.9.2. Characteristics to be respected

The axle load and axle spacing of the vehicles defines the vertical quasi-static load input to the track.

The load limits for wagons take into account their geometrical characteristics, weights per axle and weights per linear metre.

They shall be in accordance with the classification of lines or sections of lines, categories A, B1, B2, C2, C3, C4, D2, D3, D4 as defined in the table below.

It is intended that routes capable of accepting axle loads higher than 22.5 tonnes will be gradually introduced across the European railway network in accordance with the requirements of railway undertakings and the infrastructure managers. For axle loads higher than 22.5 tonnes, existing national rules continue to apply to lines capable of accepting these axle loads.

Classification	Mass per axle = P						
	A	B	C	D	E	F	G
Mass per unit length = p	16 t	18 t	20 t	22.5 t	25 t	27.5 t	30 t
1 5.0 t/m	A	B1					
2 6.4 t/m		B2	C2	D2			
3 7.2 t/m			C3	D3			
4 8.0 t/m			C4	D4	E4		
5 8.8 t/m					E5		
6 10 t/m							

p = Mass per unit length, i.e. the wagon mass plus the mass of the load, divided by the wagon length in metres, measured over the buffers when non-compressed.

P = Mass per axle.

A train made up of wagons with two 2-axle bogies in accordance with the data given in Annex D Table D.1 shall be used in order to determine the category in which a line should be classified.

A line or section of line shall be classified in one of these categories when it is capable of handling an unlimited number of wagons with the weight characteristics shown in the table above.

NOTE : As an exception 20 t axle-loads may be exceeded by up to 0.5 t on Category C lines for:

- 2-axle long wagons with $14.10 \text{ m} < \text{LOB} < 15.50 \text{ m}$ to bring their payload up to 25 t;
- wagons designed for 22.5 t axle-loads to offset the extra tare incurred in making them suitable for such axle-loads.

In practice, the maximum permissible mass per wheel shall be 11.1 t.

Classification according to the maximum mass per axle P shall be expressed in capital letters (A, B, C, D, E, F, G); classification according to the maximum mass per unit length p shall be expressed in Arabic numerals (1, 2, 3, 4, 5, 6), except for Category A.

The correspondence between classified lines and handling of wagons will be specified in the relevant TSI.

2.10. Electrical protection of the train

2.10.1. Description of the parameter

This basic parameter covers the disconnection of power supply in case of short circuit. Electrical resistance between all metal parts of the rolling stock and the rail shall be low

enough to ensure that rising short circuit current will cause disconnection of circuit line breaker (e. g. when the catenary falls on a wagon).

The return current paths and the protective bonding (earthing cable) of the vehicle shall be able to withstand the maximum short circuit current until disconnection by infrastructure circuit line breaker (substation) without damaging the current paths itself or parts of the vehicle.

2.10.2. Characteristics to be respected

2.10.2.1. General

All the metallic parts of a freight wagon that are at risk from excessive contact voltages or being at risk of causing accidents caused by electrical charges of any origin, shall be held at the same voltage as the rail.

2.10.2.2. Functional and technical specifications of the subsystem

Freight wagon bonding

The electrical resistance between the metallic parts and the rail shall not exceed 0.15 ohm for freight wagons.

These values are measured with 50 A direct current.

When materials which are poor conductors do not enable the above values to be reached, the vehicles themselves shall be fitted with the following protective bonding connections:

- The body shall be connected to the frame in at least two different points;
- The frame shall be connected to each bogie at least once.

Each bogie shall be bonded reliably by means of at least one axle box. If there are no bogies, no bonding connections are needed.

Each bonding connection shall be made of a flexible and non corrodable or corrosion protected material and have a minimum cross section according to the materials used (the reference is 35 mm² for copper).

Particularly restrictive conditions, from the point of view of eliminating risks, shall be taken in the case of special vehicles, for example roofless vehicles occupied by passengers in their own cars, vehicles used to transport dangerous good (listed in the directive 96/49 EC and its valid Annex RID.).

Freight wagon electrical equipment bonding

Where there is an electrical installation on the freight wagon, any metallic parts of the electrical equipment liable to be touched by people shall be reliably bonded, if the standard voltage to which they may be subjected is higher than:

- 50 Vdc

- 24 Vac
- 24 V between phases when the neutral point is not bonded
- 42 V between phases when the neutral point is bonded.

The cross-section of the bonding cable will depend on the current in the electrical installation, but shall be of a suitable size to guarantee reliable operation of the circuit protection devices, in the event of a fault.

Any aerials fitted outside the freight wagons shall be completely protected from the voltage of the catenary or 3rd rail and the system shall form an electrical single unit bonded at one single point. An antenna fitted outside of the freight wagon that does not conform to the previous conditions, shall be isolated.

The electrical resistance of each wheelset measured across the treads of the two wheels shall not exceed 0.01 ohm for new or reassembled wheelsets incorporating new components.

These resistance measurements are to be made using an applied voltage of 1.8 to 2.0 V.

2.11. Vehicle dynamic behaviour (wheel-rail interaction)

2.11.1. Description of the parameter

The basic parameter defines the limiting criteria to which a vehicle must conform in order to negotiate safely the track features it may experience. It includes the limiting track features against which conformance has to be assessed.

It also indicates acceptable methods of validation including analysis, laboratory tests and track tests.

2.11.2. Characteristics to be respected

2.11.2.1. General

The dynamic behaviour of a vehicle has strong effects on safety against derailment and running stability. The vehicle dynamic behaviour is determined by:

- the maximum speed
- static track features (alignment, track gauge, cant, rail inclination, discrete and periodic track irregularities)
- dynamic track features (horizontal and vertical track stiffness and track damping)
- wheel / rail contact parameters (wheel and rail profile, track gauge)
- wheel defects (wheel flats, out of roundness)
- mass and inertia of car body, bogies and wheelsets
- suspension characteristic of the vehicles
- distribution of the payload.

In order to guarantee safety and running stability, measurements in different operating conditions or comparison studies with proven design (e. g. simulation / calculation) have to be carried out to assess the dynamic behaviour.
Rolling stock must have characteristics which enable stable running within the applicable speed limit.

2.11.2.2. Functional and technical specifications of the subsystem

Safety against derailment and running stability

In order to guarantee safety against derailment and running stability the forces between wheel and rail have to be limited. In particular, the forces in question are transverse track forces Y and vertical forces Q.

- **Lateral track force Y**

In order to prevent track shifts, interoperable rolling stock shall comply with the Prud'homme criteria for the maximum transverse force

$$(\Sigma Y)_{\text{lim}} \text{ or } (H_{2\text{m}})_{\text{lim}}$$

$(H_{2\text{m}})$ is the floating mean value of the lateral force in an axle measured over 2 m)

This value will be given by the TSI Infrastructure; until that time national rules will apply.

In curves, the limit of the quasi-static lateral force on the outer wheel is

$$Y_{\text{qst,lim}}$$

This value will be given by the TSI Infrastructure; until that time national rules will apply.

- **Y/Q forces**

To limit the risk of wheel climb on the rail the quotient of lateral force Y and vertical load Q of a wheel must not exceed

$$(Y/Q)_{\text{lim}} = 0.8 \text{ for large curves } R \geq 250 \text{ m}$$

$$(Y/Q)_{\text{lim}} = 1.2 \text{ for small curves } R < 250 \text{ m}$$

- **Vertical force**

The maximum dynamic vertical force exerted on the rail is

$$Q_{\text{max}}$$

This value will be given by the TSI Infrastructure; until that time national rules will apply.

In curves the limit of the quasi-static vertical force on the outer wheel is

$$Q_{\text{qst,lim}}$$

This value will be given by the TSI Infrastructure; until that time national rules will apply.

Safety against derailment when running on twisted tracks

Wagons are able to run on twisted tracks when (Y/Q) does not exceed the limit given here-above in a curve of radius $R = 150 \text{ m}$ and for a given twisted track:

for a wheel base of $1.3 \text{ m} \leq 2a^* \leq 20 \text{ m}$

$$g_{\text{lim}} = 20/2a^* + 3$$

$$g_{\text{lim}} \leq 7\text{‰}$$

With a wheelbase of $2a^* > 20$ m, the limit value $g_{\text{lim}} = 3\text{‰}$.

The wheelbase $2a^*$ represents the axle spacing for 2-axle wagons or the distance between the pivot centres of a bogie wagon.

Maintenance rules

The following key parameters essential for safety and running stability shall be maintained according to the maintenance plan:

- suspension characteristics
- body-bogie connections
- tread profile.

The maximum and minimum dimensions for wheelsets and wheels for standard gauge will be given in the Freight wagons TSI.

2.12. Longitudinal compressive Forces

2.12.1. Description of the parameter

This parameter describes the maximum longitudinal compressive force which can be applied on an interoperable freight wagon or an individual vehicle of an interoperable train-set during braking or during a pushing operation, without any risk of derailment.

2.12.2. Characteristics to be respected

2.12.2.1. General

When subjected to longitudinal compressive forces, the wagon has to continue to run safely. In order to guarantee safety against derailment, the wagon or system of coupled wagons has to be assessed by tests, calculations or through comparison with the characteristics of approved (certified) wagons.

The longitudinal force that can be applied on a vehicle without derailing has to be higher than a threshold value depending on the vehicle design (two axle, bogie wagon, fixed group of vehicles, Combirail, Road- Railer™, etc.) fitted with UIC coupler or accepted central coupler or coupling rod/short couplers.

The conditions to certify the wagons, fixed groups of wagons and coupled groups of wagons are given in the following section.

The conditions that affect the maximum longitudinal compressive force that a wagon is capable of withstanding without derailment include:

- cant deficiency
- train and wagon braking system
- system of draw gear and buffers on the wagons or specially coupled wagon-groups
- design characteristics of the wagon
- characteristics of the line
- train driver's handling of the train, especially braking

- wheel / rail contact parameters (wheel and rail profile, track gauge)
- load distribution of the individual freight wagons.

The longitudinal compressive force has a strong effect on safety against derailment of a vehicle. Therefore measurements in different operating conditions have been carried out to find the acceptable limits of longitudinal compressive force that can be applied on a vehicle without risk of derailment. Experience with different wagon-types has resulted in different methods of acceptance depending on factors such as tare weight, length, wheelbase, overhang, distance between pivots etc. To avoid tests the wagons have to correspond with the characteristics of previously approved wagons, or been built due to approved design characteristics of wagons and fitted with approved components such as certified bogies.

2.12.2.2. Functional and technical specifications of the subsystem

The subsystem shall withstand the longitudinal compressive forces in the train without derailing or damaging the vehicle. In particular the determining factors are the following:

- transverse wheel / rail forces -Y-
- vertical forces -Q-
- lateral forces on axle-boxes -H_{ij}-
- braking forces (due to wheel / rail contact, dynamic braking and different braking groups of the wagons and trains)
- diagonal and vertical buffer forces
- coupling forces ±Z
- damping of buffer- and coupling forces
- the result of coupler tightness
- the result of coupler slack
- jerks as a result of longitudinal movements in the trains and coupler slack
- wheel lift
- axle guide deflection

Longitudinal Compressive Forces (LCF) are influenced by many factors. The different factors are given in the documents for construction and operating conditions of wagons to which it is necessary to certify wagons for normal traffic on different lines and under different conditions.

In order to certify wagons for mixed traffic on the European Network, it has been clarified through tests on special testing track and in running trains on different lines that wagons can withstand a minimum longitudinal force, without derailing. The following definition was made:

Freight wagons fitted with screw couplings and side-buffers as well as compositions of freight wagons fitted with screw couplings and side-buffers at their outer ends and coupling rod/short coupler between the units, must withstand independently from their type, a minimum longitudinal force measured in the conditions of the reference test of:

- 200 kN for two-axle freight wagons with UIC coupling
- 240 kN for freight wagons fitted with two-axle bogies with UIC coupling
- 500 kN for freight wagons with all types of central bar couplers and without buffers.

For other coupling systems, limit values are not yet defined.

2.12.2.3. Maintenance rules

If the bufferheads have to be lubricated in order to ensure the required coefficient of friction, then the maintenance plan shall include provision for maintaining the coefficient of friction at this level.

2.13. Braking performance

2.13.1. Description of the parameter

Braking performance of a train or a vehicle is the result of a process of retarding the train within defined limits. It covers all factors involved in the conversion and dissipation of energy and includes train resistance. Individual vehicle performance is defined so that the overall braking performance of the train can be derived operationally.

Braking performance for an individual vehicle has to be determined for

- Emergency brake,
- Full service brake.

Braking performance is fully defined by:

- Deceleration curve (deceleration = $f(\text{speed})$, at the minimum: mean deceleration (= average deceleration)),
- Time delay (time delay covers signal transmission delay and a ratio of application-time),
- Minimum deceleration at any points during the braking process (e. g. to counter gradient effects),
- Differentiation between Emergency and Full Service braking.

2.13.2. Characteristics to be respected

2.13.2.1. General

The purpose of the train braking system is to ensure that the train speed can be reduced or can be stopped within the maximum allowable braking distance. The primary factors that influence the brake process are the braking power, the speed, the allowable braking distance, the adhesion and the track gradient.

Braking performance of a train or a vehicle is the result of the braking power available to retard the train within defined limits and all factors involved in the conversion and dissipation of energy including train resistance. Individual vehicle performance is defined so that the overall braking performance of the train can be derived operationally.

Vehicles must be equipped with continuous automatic brake.

A brake is continuous if it allows the transmission of signals and energy between adjacent vehicles when coupled in a train.

A continuous brake is automatic, if it becomes effective immediately on the whole train with every inadvertent break of the control train line, e. g. brake-pipe.

Where it is not possible to detect the state of the brake, an indicator showing the state shall be provided on both sides of the vehicle.

The brake energy storage (e.g. supply reservoirs of indirect pneumatic air brake system, brake pipe air) and the brake energy used to build up the brake effort (e.g. air from brake cylinders of indirect pneumatic air brake system) shall be used only for braking use.

2.13.2.2. Functional and Technical Specification of braking performance

Control train line

The minimum propagation signal speed shall be 250 m/s.

Braking Performance elements

Braking performance shall take into account mean application time, instantaneous deceleration, mass and initial speed. Braking performance shall be determined by both deceleration profiles and by braked weight percentage and / or brake force.

Deceleration profile

The deceleration profile describes the predicted instantaneous deceleration of the vehicle (at the level of a vehicle) or the train (at the level of a train) in normal conditions. The deceleration profile of the train is to be calculated from knowledge of all individual deceleration profiles of the train's vehicles. The deceleration profile includes the effect of:

- a) the response time between brake demand and reaching full brake effort.

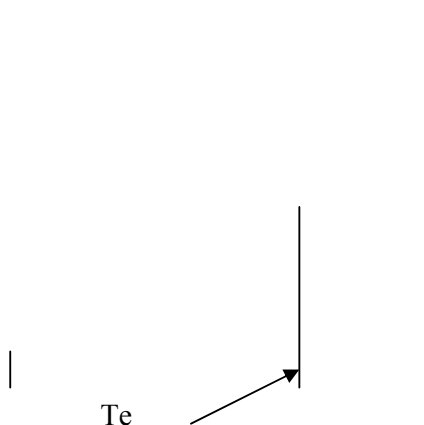

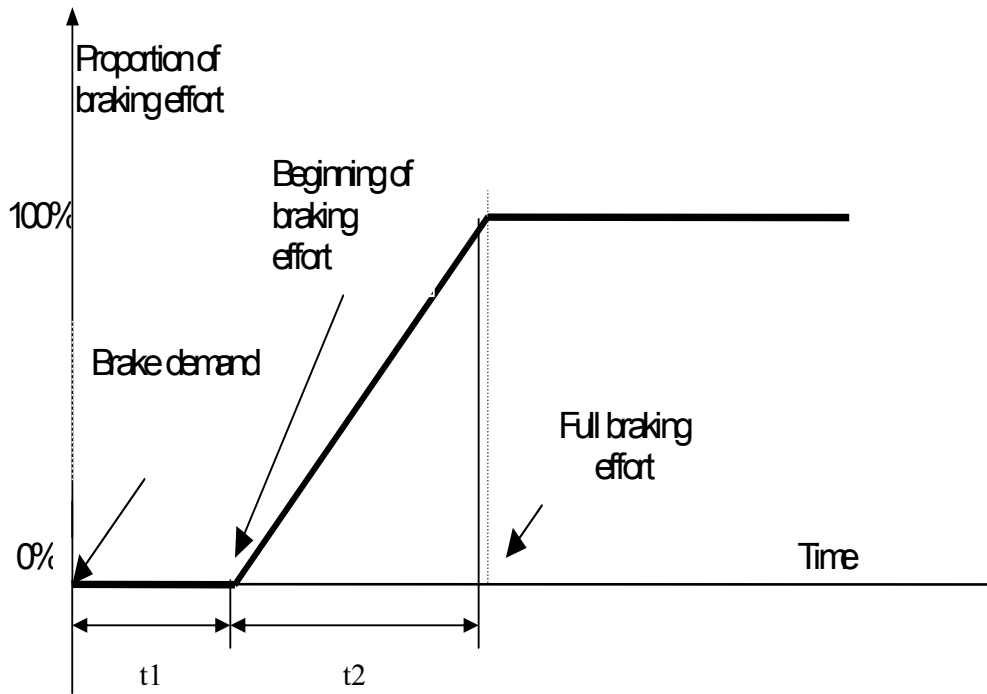

T_e is the equivalent build-up application time and is defined as:

$$T_e = t_1 + (t_2 / 2)$$

For pneumatic brake the end of the time t_2 corresponds to 95% of established brake cylinder pressure.

b) the corresponding function (*deceleration = $F(\text{speed})$*) as defined as a succession of sections with a constant deceleration.

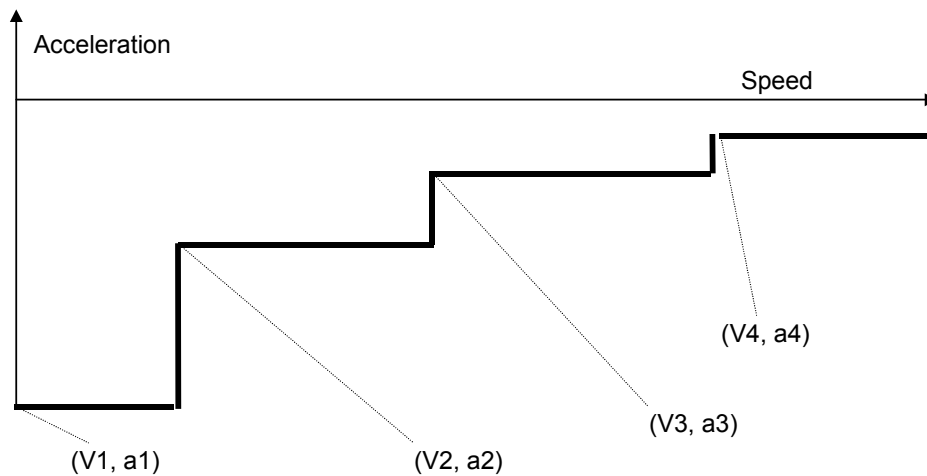

Note: a denotes the instantaneous deceleration and V the instantaneous speed

Brake mass percentage

The brake mass percentage (λ) is the ratio of the sum of the brake masses divided by the sum of the masses of the vehicles.

The method of determining the brake mass / brake mass percentage shall remain applicable beside the method of deceleration profiles. So both methods shall be required, and the manufacturer shall supply these values. This information is required to be entered in the Rolling Stock Register.

Braking power for an individual vehicle shall be determined in emergency braking for each braking mode (e.g. G, P, R, P + Ep) available on the vehicle and for several loading conditions including at least the tare and the full load.

G braking mode

Brake mode used for freight trains with specified brake application time and brake release time.

P braking mode

Brake mode for passenger trains and freight trains with specified brake application time and brake release time and specified brake mass percentage.

R braking mode

Brake mode for passenger trains and fast freight trains with specified brake application time and brake release time as braking mode P and specified brake mass percentage.

Ep brake (indirect Electro-pneumatic brake)

Assistance to indirect air brake that uses an electrical command on the train and electro-pneumatic valves on the vehicle and thus starts operating more rapidly and less jerkily than the conventional air brake.

Emergency braking

Emergency braking is a brake command that stops the train to ensure the specified level of safety without any brake system degradation.

The minimum braking performance for brake-modes G and P shall be in accordance with the following table :

Braking mode	Te (s) (range)	Speed limit 100 km/h		Speed limit 120 km/h	
		lambda Braking distance	Minimum mean deceleration	lambda Braking distance	Minimum mean deceleration
Case A: empty	1.5 – 3	100 % 480 m	0,91	100 % 700 m	0.88
Case B: Brake only on wheels loaded at 18 t per wheelset	1.5 – 3			100 % 700 m	0.88
Case C:	1.5 – 3			90 %	0.80

Brake only on wheels loaded at 20 t per wheelset				765 m	
Case D: Full loaded (other cases)	1.5 – 3	65 % 700 m	0.6	100 % 700 m for disk brakes ¹	0.88
G	9 – 15	There shall be no separate assessment of the braking power of wagons in position G. A wagon's braked mass in position G shall be the same as braked mass in position P.		Not applicable	

Te: Equivalent Build-up-time of application and half the individual vehicle response time for single-pipe freight wagons.

This table is based on a reference speed of 100 km/h and an axle load of 22.5 t, and 120 km/h and an axle load of 20 t. Higher axle loads can be accepted under specific operational conditions. The permitted maximum axle load shall be in accordance with the infrastructure requirements.

In braking mode P and G, lambda shall be not higher than 130 % in all cases without wheel slide protection (WSP) (especially important in the empty state).

2.13.2.3. Mechanical components

A device to automatically maintain the design clearance between the friction pair is mandatory.

2.13.2.4. Energy storage

The energy storage shall be sufficient to obtain during an emergency braking at maximum speed, whatever the loaded state of the vehicle, the maximum brake effort without any further supply of energy (e.g. for indirect compressed air brake system: brake pipe only without replenishment by main reservoir pipe). When a vehicle is equipped with WSP the above condition applies with the WSP fully operational (e.g. WSP air consumption).

¹ 80% for wagons with only shoe brakes; the charge is then limited to 18 t.

2.13.2.5. Energy limits

The brake system shall be designed to allow the vehicle to run on all existing lines of the whole trans-European conventional rail system.

The brake system must stop the vehicle loaded and maintain the speed of the vehicle without any thermal or mechanical damage in these following conditions:

1. 2 successive emergency braking from the maximum speed on straight and flat track with minimum wind and dry rail;
2. Maintain a speed of 80 km/h in a slope with a mean declivity of 21 ‰ and a length of 46 km (the south slope of St Gotthard's line between Airolo and Biasca is the reference slope).

2.13.2.6. Wheel slide protection (WSP)

Wheel slide protection (WSP) is a system designed to make the best use of available adhesion by a controlled reduction and restoration of the brake force to prevent wheel sets from locking and uncontrolled sliding, thereby optimising stopping distance. The WSP shall not alter the functional characteristics of the brakes. The vehicle's air equipment shall be dimensioned such that the air consumption of the WSP does not impair the performance of the pneumatic brake. The WSP shall not have a detrimental effect on the constituent parts of the vehicle (brake gear, wheel tread, axle boxes, etc).

The use of a WSP is mandatory for wagons:

- a) equipped with brake blocks made of cast iron or sintered material, for which the maximum mean utilisation of adhesion (δ) is greater than 15 % starting from a speed of 120 km/h ($\lambda \geq 160$ %). The maximum mean utilisation of adhesion is shown by calculating the maximum mean adhesion (δ) from individual braking distances obtained from the possible range of vehicle mass. δ is therefore related to the measured braking distances necessary for determining the braking performance ($\delta = f(V, T_e, \text{stopping distance})$).
- b) equipped with disc brakes only or composite blocks, for which the maximum utilisation of adhesion (see above for the definition of the maximum utilisation of adhesion (δ)) is greater than 11 % at a speed of 120 km/h ($\lambda \geq 125$ %).
- c) With maximum operating speed ≥ 160 km/h.

2.13.2.7. Air-supply

Freight wagons shall be designed to be able to work with compressed air compliant at least with class 4.4.5 as defined by ISO 8573-1.

2.13.2.8. Parking Brake

A parking brake is a brake used to prevent parked rolling stock moving under the specified conditions taking into account the place, wind, gradient and rolling stock state, until intentionally released.

It is not compulsory for all wagons to be equipped with a parking brake. Operational rules, taking into account the fact that not all wagons in a train are equipped with these brakes, are described in the Traffic Operation and Management TSI (e.g. train composition rules and other means to immobilise the train).

If the wagon is equipped with a parking brake, it shall meet the following requirements.

The power source for providing the parking brake effort shall be derived from a different power source than the automatic service / emergency brake.

The parking brake shall operate on at least half of the wheelsets, with a minimum of 2 wheelsets per wagon.

Where it is not possible to see the state of the parking brake, an indicator showing the state shall be provided on both sides on the outside of the vehicle.

The wagon parking brake shall be accessed and operated from the ground or on the vehicle. Handles or hand wheels shall be used to operate the parking brake, but only hand wheels may be used for brakes operated from the ground. Parking brakes that are accessible from the ground shall be available on both sides of the vehicle. Handles or hand wheels shall apply the brakes when they are turned in a clockwise direction.

Where the parking brake controls are fitted inside a vehicle, they shall be accessible from both sides of the vehicle. Where the parking brake can be superimposed with other brake applications, either whilst moving or statically, the vehicle equipment shall be able to withstand the imposed loads for the life of the vehicle.

It shall be possible to release the parking brake manually in an emergency situation at standstill.

The parking brake shall conform to the table below.

Wagon not specifically listed below	At least 20% of a keeper's fleet with the parking brake operated from the wagon (platform or gangway) or the ground, spread over the greatest possible number of types of wagons
Wagons built specifically for the transport of loads requiring precautions as follows or / and according to Council	One per wagon operated from the vehicle (platform or gangway)

Directive 96/49/EC (RID): livestock; fragile loads; compressed or liquefied gases; materials which give off inflammable gases when in contact with water causing combustion; acids; corrosive or combustible liquids; loads igniting spontaneously, catching fire or exploding easily	
Wagons whose special fittings for accommodating the load must be treated with caution, i.e. carboy, jar or cask wagons; tanks of aluminium; tanks lined with ebonite or enamel; crane wagons (or / and according to Council Directive 96/49/EC (RID))	One per wagon operated from the wagon (platform or gangway)
Wagons with a superstructure built specifically for the transport of road vehicles, including the multi-deck wagons for the transport of motor cars	One per wagon operated from the wagon (platform or gangway) and 20% of these having the parking brake also operated from the wagon floor
Wagons for the transport of demountable swap bodies for horizontal transshipment	One per wagon operated from the ground
Wagons comprising several permanently coupled units	A minimum of two axles (on one unit)

The parking brake shall be designed such that fully loaded wagons shall be held in a gradient of 4.0 % with maximum adhesion of 0.15 with no wind.

2.14. Vehicle capability to transmit information between ground and vehicle

2.14.1. Description of the parameter

This basic parameter indicates the required minimum capabilities of data transmission between vehicle and ground. This capability may range from simple vehicle identification (e.g., wagon number) to complex data exchange processes, e.g., needed to support load monitoring, fleet management, etc.

2.14.2. Characteristics to be respected

2.14.2.1. General

Application of tags is not mandatory. If a wagon is fitted with radio-frequency identification devices (RFID-tag), the following specification shall be applied.

2.14.2.2. Functional and technical specification of the subsystem

Two "passive" tags shall be fitted, one on each side of the wagon in the areas indicated in the following figure 2, such that the unique identification number of the wagon can be read by a trackside device (the *tag reader*).

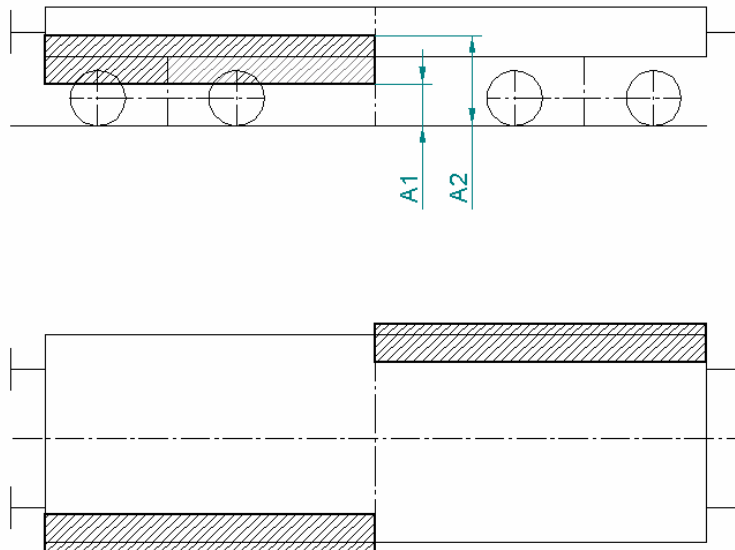

Fig. 2 Tag position on wagon

When available, trackside devices (*tag readers*) shall be capable of decoding tags passing at a speed of up to 30 km/h and make this decoded information available to a ground-based data transmission system.

Typical installation constraints are given in [figure 3](#) where the reader position is defined by a cone.

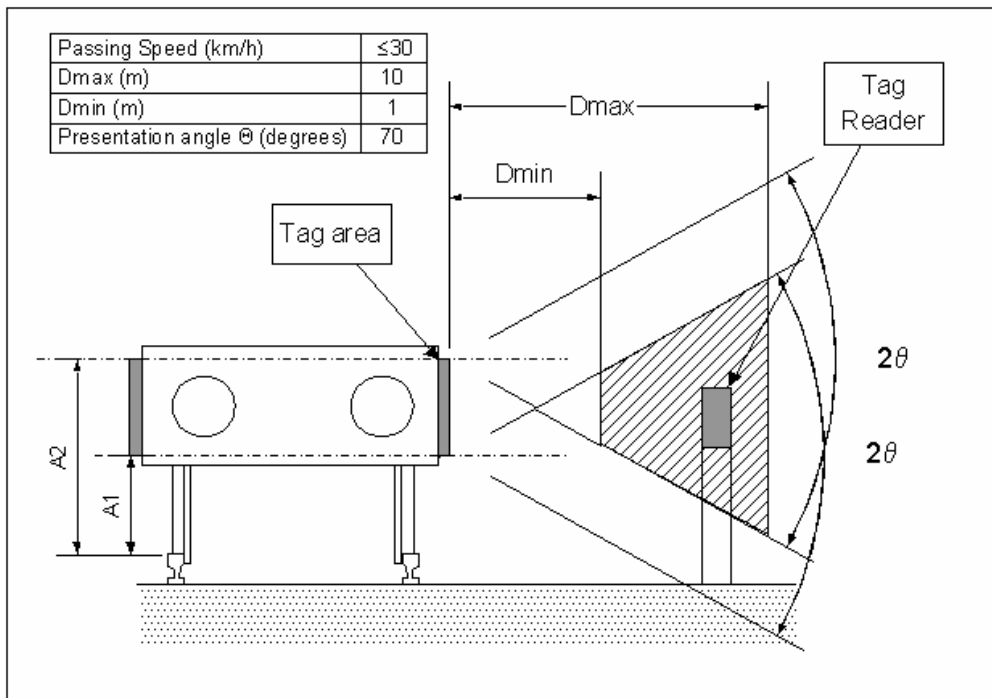

Fig. 3 - Installation constraints for tag readers

The physical interactions between the reader and the tag, the protocols and the commands, and the collision arbitration schemes, shall conform to ISO18000-6 type A. When fitted, tag readers shall be positioned at entry and exit points of locations where train formation can be changed.

The tag reader shall provide at a minimum to the interface with any data transmission system the following:

- Unambiguous identification of the tag reader, among those that may be installed in the same location, in order to identify the track being monitored,
- Unique identification of every wagon passing,
- Time and date for each wagon passing.

Time and date information shall be accurate enough in order that a subsequent processing system is able to identify the actual physical train composition.

2.14.2.3. Maintenance rules

Inspections according to the maintenance plan shall include:

- presence of tags,
- correct response,
- processes to ensure that tags will not be degraded during the maintenance procedures.

2.15. Environmental conditions for rolling stock (Range of functioning of components)

2.15.1. Description of the parameter

It specifies the range of functioning of rolling stock components. It may be expressed in classes for temperature etc. thereby giving the choice for the operator / manufacturer to build a vehicle suitable for operation all over Europe, as the automotive industry is doing, or have a restricted use.

The different environmental conditions of the lines are defined in the "Register of Infrastructure".

2.15.2. Characteristics to be respected

2.15.2.1. General

The rolling stock, as well as the on-board equipment, shall be able to be put into service and operate normally in the conditions and climatic zones for which the equipment is designed and in which it is likely to run.

The environmental conditions are expressed in classes for temperature etc. thereby giving the choice for the operator to procure a vehicle suitable for operation all over Europe, or have a restricted use.

The "Register of Infrastructure" will specify the ranges of environmental conditions likely to be experienced on the individual lines. The same ranges will be used to assist reference to operating rules.

The range limits specified are those which have a low probability of being exceeded. All specified values are maximum or limit values. These values may be reached, but do not occur permanently. Depending on the situation there may be different frequencies of occurrence related to a certain period of time.

2.15.2.2. Functional and technical specifications of the subsystem

Altitude

The wagons shall perform as specified for all altitudes up to 2000 m.

Temperature

Classes	Design level classes
T _{RIV}	Subsystems and components have different temperature requirements. Details will be given in the relevant TSI
	Air temperature range external to vehicle [°C]:
T _n	-40 +35

Ts	-25 +45
----	---------

The class T_{RIV} is identical to the temperature design level of all interoperable wagons existing before implementation of the relevant TSI. The design level for class T_{RIV} will be given in the relevant TSI.

All freight wagons intended for international traffic shall comply as a minimum with temperature class T_{RIV} .

In addition to design level class T_{RIV} the external temperature classes Ts and Tn exist.

A T_{RIV} wagon is permitted to operate in:

- permanent use on Ts lines;
- permanent use on Tn lines in the period of the year when temperature is expected to be above $-25\text{ }^{\circ}\text{C}$;
- non-permanent use on Tn lines in the period of the year when temperature is expected to be below $-25\text{ }^{\circ}\text{C}$.

Remark: it will be the choice of wagon buyer to decide the additional temperature range of the wagon according to its intended use (Tn, Ts, Tn + Ts, or nothing more than T_{RIV}).

Humidity

The following external humidity levels shall be considered:

Yearly average: $\leq 75\%$ relative humidity;

On 30 days in the year continuously: between 75% and 95% relative humidity;

On the other days occasionally: between 95% and 100% relative humidity;

Maximum absolute humidity: 30 g/m^3 occurring in tunnels.

An operationally caused infrequent and slight moisture condensation shall not lead to any malfunction or failure.

The relevant TSI will specify the range of variation of the relative humidity for the different temperature classes that it is considered will not be exceeded for more than 30 days per year.

At cooled surfaces, 100% relative humidity may occur causing condensation on parts of equipment; this shall not lead to any malfunction or failure.

Sudden changes of the air temperature local to the vehicle may cause condensation of water on parts of equipment with rate of 3 K/s and maximum variation of 40 K.

These conditions particularly occurring when entering or leaving a tunnel shall not lead to any malfunction or failure of the equipment.

Rain

Rain rate of 6 mm/min shall be taken into account. The effect of rain shall be considered depending on the equipment installation together with wind and vehicle movement.

Snow, ice and hail

Consideration shall be given to the effect of all kind of snow, ice and / or hail. The maximum diameter of hailstones shall be taken as 15 mm, larger diameter may occur exceptionally.

Solar radiation

Equipment design should allow for direct exposure to solar radiation at the rate of 1120 W/m² for a maximum duration of 8h.

Pollution

The effects of pollution shall be considered in the design of equipment and components. The severity of pollution will depend upon the location of the equipment. Means may be provided to reduce pollution by the effective use of protection. The effects of the following kinds of pollution shall be considered:

Chemically active substances	Class 5C2 of EN 60721-3-5:1997
Contaminating fluids	Class 5F2 (electrical engine) of EN 60721-3-5:1997 Class 5F3 (thermal engine) of EN 60721-3-5:1997
Biologically active substances	Class 5B2 of EN 60721-3-5:1997.
Dust	Defined by class 5S2 of EN 60721-3-5:1997
Stones and other objects	Ballast and other of maximum 15 mm diameter
Grasses and leaves, pollen, flying insects, fibres etc.	For the design of ventilation ducts
Sand	According to EN 60721-3-5:1997
Sea spray	According to EN 60721-3-5:1997 Class 5C2

2.16. Emergency Exits and Signposting

2.16.1. Description of the parameter

The basic parameter gives provisions on

- Safety instructions for staff:
 - Safety instructions containing all information needed for the staff to prevent and handle an emergency situation;
 - Instructions for the safety training of staff (plan, documentation, training).

- Traffic management and rescue instruction for operation:
 - Documents for definition of the location and operation of the emergency and recovery features of the vehicle have to be provided. This is needed for the Infrastructure manager and the rescue coordination centre and services.

2.16.2. Characteristics to be respected

There is no requirement for emergency exits or signposting relating to emergency exits on freight wagons. However, in the event of an accident, there is a requirement for a rescue plan and related information notices.

Freight wagons shall have pictograms attached, as specified in paragraph relating to Marking of Wagons, indicating where the wagon may be lifted, and whether the running gear requires detaching before lifting takes place.

2.17. Fire Safety

2.17.1. Description of the parameter

The basic parameter includes the measures to guarantee a suitable safety level to prevent fire and manage the consequences in the event of fire. It may include e.g. design measures to avoid fire-ignition and -propagation.

2.17.2. Characteristics to be respected

2.17.2.1. General

- Design shall limit fire ignition and propagation;
- No toxic fume requirements shall be taken in account;
- The goods carried on freight wagons should not be taken into account – neither as a primary ignition source nor as a mean of feeding fire propagation. In case of dangerous goods carried on freight wagons only RID requirements shall be applied to them in all aspects of fire safety;
- The goods of freight wagons shall be protected against foreseeable sources of ignition on the vehicle;
- The material used on freight wagons shall limit the generation, propagation of fire, and production of smoke in the event of fire on primary ignition source of 7 kW during 3 min;
- The design rules shall be applied for any fixed equipment of the vehicle, if it is a potential source of fire ignition, e.g. cooling devices containing fuel;
- A member state shall not require smoke detectors to be installed on freight wagons.

2.17.2.2. Technical specification for freight wagons

Definitions

Fire integrity

Is the ability of a separating construction element, when exposed to fire on one side, to prevent the passage through it of flames, hot gases and other fire effluents or the occurrence of flames on the unexposed side.

Thermal insulation

Is the ability of a separating construction element to prevent excessive transmission of heat.

Normative References

- 1 EN 1363-1 Fire resistance tests
October 1999 Part 1: General requirements
- 2 EN ISO 4589-2 Determination of burning behaviour by oxygen index –
October 1998 Part 2: Ambient temperature test
- 3 ISO 5658-2 Reaction to fire tests – Spread of flame
1996-08-01 Part 2 Lateral spread on building products in vertical configuration
- 4 EN ISO 5659-2 Plastic – Smoke generation
October 1998 Part 2: Determination of optical density by a single chamber test
- 5 EN 50355 Railway applications – Railway rolling stock cables having
November 2002 special fire performance – Thin wall and standard wall – Guide to use
- 6 EN ISO 9239-2 Reaction for fire tests for flooring-
December 2003 Part 2 Determination of flame spread at a heat flux level at 25 kW m²

Design rules

Spark protection of the load shall be provided separately where the floor does not provide that protection.

The underside of the vehicle floor, in those locations where it is exposed to potential sources of fire and when spark protection is not provided, shall be provided with thermal insulation and fire integrity.

Material requirement

In the following table the parameters used to define requirements and their characteristics, are listed. Also stated is whether the numerical value in the tables of requirements represents a maximum or minimum for compliance.
A reported result equal to the requirement is compliant.

Test Method	Parameter	Units	Requirement definition
EN ISO 4589-2 [2]	LOI	% Oxygen	minimum
ISO 5658 [3]	CFE	kWm ⁻²	minimum

EN ISO 9239-2 [6]	CFE	kWm^{-2}	minimum
EN ISO 5659-2 [4]	$D_{s \max}$	Dimensionless	maximum

Minimum Requirements

Parts or materials having a surface area less than the surface classification below, shall be tested with minimum requirements.

Test Method	Parameter	Unit	Requirement
EN ISO 4589-2 [2]	LOI	% Oxygen	≥ 26

Requirements for material used as surface except floors

Method : Conditions Parameter	Parameter	Unit	Requirement
ISO 5658-2 [3] CFE	CFE	kWm^{-2}	≥ 24
EN ISO 5659-2 [4] 50kWm^{-2}	$D_s \max$	Dimensionless	≤ 600

Requirements for material used as surface for floor

Method : Conditions Parameter	Parameter	Unit	Requirement
EN ISO 9239-2 [6] CFE	CFE	kWm^{-2}	≥ 4.5
EN ISO 5659-2 [4] 50kWm^{-2}	$D_s \max$	Dimensionless	≤ 600

Surface classification

All materials used shall meet the minimum requirements where the surface area of the material / item is less than 0.25m^2 and

- on a ceiling:

- the maximum dimension in any direction on the surface is less than 1m and
- the separation from another surface is greater than the maximum extent of the surface (measured horizontally in any direction on the surface);
- on a wall and the floor :
 - the maximum dimension in a vertical direction is less than 1m and
 - the separation from another surface is greater than the maximum extent of the surface (measured vertically for walls or horizontally for floors).

Cable requirements

Cable used for electrical installation on freight wagons shall be in accordance with EN 50355 [5]. For fire safety requirements the hazard level 3 shall be taken in account.

Maintenance of the fire protection measures

The condition of fire integrity and thermal insulation measures of the freight wagons (e.g. floor protection, wheel spark protection) shall be checked every overhaul period and intermediate periods where it is appropriate to the design solution and field experience.

3. BASIC PARAMETERS RELATED TO THE TSI ON TELEMATIC APPLICATIONS FOR FREIGHT

3.1. Consignment Note data

3.1.1. Description of the parameter

The Consignment Note has to be sent by the Customer to the Lead RU (LRU). It must show all the information needed to carry a consignment from the consignor to the consignee. The LRU must supplement this data with additional information.

These data are the basis for a path request on short notice, if this is required for the execution of the consignment note.

3.1.2. Characteristics to be respected

Wagon order

The wagon order is primarily a subset of the Consignment Note information.

The main content of the wagon order is:

- Consignor and consignee information
- Routing information
- Consignment identification
- Wagon information
- Place and time information

Data exchange in case of Open Access

In the case of Open Access no message exchange is needed with other RUs.

Data exchange in case of Co-operation mode

In the case of co-operation with various RUs, the LRU must send Wagon Orders to the RUS involved in the transport chain. The Content of Wagon Order must show the relevant information which is needed for an RU to effect transportation during its responsibility until handover to next RU. Therefore the content is dependent on the role to be performed by the Railway Undertaking: Origin-, Transit- or Delivery RU (ORU, TRU, DRU).

Wagon order messages

The following Wagon Orders must be distinguished:

- Wagon Order for the Origin Railway Undertaking (ORU);
- Wagon Order for the Delivery Railway Undertaking (DRU);
- Wagon Order for the Transit Railway Undertaking (TRU).

3.2. Path Request

3.2.1. Description of the parameter

Here the dialogue between RUs and IMs to get the agreement of a train movement at short notice is described. This dialogue is stated by an RU but will involve all RUs and IMs necessary in moving the train along the desired path.

3.2.2. Characteristics to be respected

Train Path

The Train Path defines the requested, accepted and actual data to be stored concerning the path of a train and the characteristics of the train for each segment of that path.

Long term planning

The long term planning of paths (timetables) is out of the scope of the TSI.

Path Request on short notice

Due to exceptions during the train running or due to transport demands on a short time basis, a Railway Undertaking must have the possibility to get an ad hoc path on the network.

In the first case, immediate actions have to be started, whereby the actual train composition based on the train composition list is known.

In the second case, the Railway Undertaking must provide the Infrastructure Manager with all necessary data concerning when and where the train is required to run together with the physical characteristics in so far as they interact with the infrastructure. These data are mainly given in the supplemented consignment note, respectively in the wagon orders.

Open Access

The RU contacts all involved IMs directly or via the One Stop Shop (OSS) to organise the paths for the complete journey. In this case the RU has also to operate the train on the complete journey according to Article 13 of the Directive 2001/14/EC.

Co-operation Mode

Each RU involved in the Transport Journey from A to B contacts the local IMs directly or via OSS to request a path for the journey section on which it operates the train.

Path request dialog for short notice

In both scenarios the booking procedure of a path on short notice follows the dialog between RU and IM involved as described below:

Path Request

RU to IM(s) involved, this message must be sent for a path request at short notice.

Path Details

This message must be sent from IM(s) to RU confirming details of path in response to RU's "Path Request", perhaps with changed values.

Path Confirmed

This message must be sent from the RU to the IM for the acceptance of the "Path Details" from the IM in response to the RU's original request.

Path Details Refused

This message must be sent from the RU to the IM when not accepting the "Path Details" from the IM in response to RU's original request, if there are changed values, which the RU cannot accept.

Path Cancelled

Advice from the RU to the IM to cancel a previously booked path or a part of it.

Path Not Available

Advice from the IM to the RU that the booked path is not available (cancellation of a booked path by IM).

Receipt Confirmation

This message must be sent from the recipient of a message to the originator of the message when the required response cannot be made available in real-time.

3.3. Train Preparation

3.3.1. Description of the parameter

This parameter specifies the messages which must be exchanged during the train preparation phase until the start of the train. This parameter contains three groups of data:

- Train composition relating to the make up of the train and its actual characteristics. This is made available to all IMs and RUs involved with the train;
- Reaction of the IM, when receiving the train composition;
- The dialogue between IM and RU for each segment on the train journey that is necessary when the train is ready.

3.3.2. Characteristics to be respected

Access to registers and Reference files

For the preparation of the train, the RU must have access to the actual infrastructure data (infrastructure register), to the dangerous goods reference file, to the technical wagon data and to the current, updated information status on the wagons. This refers to all wagons on the train.

Conditions for sending the train composition

If the train composition is changed at a location, this message must be exchanged once more to all parties involved with information updated by the RU.

The train composition message

The train composition message must contain all data required for safe and efficient traffic. These are the data concerning the physical characteristics of a train in so far as these interact with the infrastructure network over which it is to run.

IM reactions on the train composition

Train accepted

Depending on the contractual agreement between the IM and the RU and on regulatory requirements, the IM may also advise the RU if the train composition is acceptable for the booked path. This is effected with this message. This message is optional, if nothing else is agreed between IM and RU. The train preparation can be completed.

Train not Suitable

If the train is not suitable for the previously agreed path, the IM must inform the RU, with this message. In this case the RU has to recheck the train composition or to cancel the train path and to request new path.

Train start dialogue

At each point where the responsibility changes on the RU side, the start procedure dialogue is obligatory.

Train ready

This message must be sent from RU to IM indicating that the train is ready for access to the network.

Train Position

This message may be sent from the IM to the RU defining exactly when and where the train should present itself to the network as an answer to the train ready message. The transmission of this message depends on the contractual arrangement between the RU and the IM.

Train at Start

This message may be sent from the RU to the IM when having received a “train position” message from the IM, to indicate that the train has started its journey. This message must have an identifier to which it refers.

Train Running Advice

IM to RU, this message must be sent to indicate that the train has arrived on the infrastructure

3.4. Train Running Forecast

3.4.1. Description of the parameter

This parameter describes the messages issued by the IM to the RU and also exchanged between the IMs involved at agreed reporting points.

Train Running Forecast

The message contains the forecasted time of the train at a specified location e.g. if the specified location is a hand over point, then the forecasted time is the ETH (Estimated Time of Handover). For all other reporting points the forecasted time is TETA (Train Estimated Time of Arrival)

Train Running Advice

The message contains the actual arrival time, departure time or pass-through time of a train at a specified location together with the deviation against schedule.

3.4.2. Characteristics to be respected

Open Access

In the case of Open Access, which means that the paths for the complete journey are booked by one RU (this RU also operates the train during the complete journey), the messages are sent to this RU. The same is true, if the paths for the journey are booked by one RU via OSS.

Co-operation mode

In the case of Co-operation mode, this information exchange between RUs and IMs always takes place between the IM in charge and the RU, who has booked the path on which the train is actually running.

Approaching scenario

The following scenarios will be differentiated, taking into account the various communication relations between RUs and IMs according to the path booking:

- Train Approaching a Handover Point between IM n°1 and his neighbour IM n°2. The Handover point is not also an Interchange or Handling Point;
- Train Approaching an Interchange Point between RU 1 and the next RU 2. The interchange point may also be a handover point between e.g. IM n°1 and IM n°2;
- Train Approaching a Handling Point of an RU;
- Train arrival at Destination.

3.5. Service Disruption Information

3.5.1. Description of the parameter

This parameter describes the handling and the message exchange in case of any service disruption during train running.

3.5.2. Characteristics to be respected

Temporary disruption in responsibility of the RU

When the RU learns about a service disruption during the train running operation for which it is responsible, it immediately informs the IM (no IT-Message e.g. from the driver).

Temporary disruption in responsibility of the IM

If the delay exceeds x minutes (this value must be defined in the contract between RU and IM) the IM concerned must send to the RU a train running forecast message relating to the next reporting point.

Cancellation of the train

If the train is cancelled, the IM sends to the neighbouring IM and to the path contracted RU a

- train running interrupted message.

3.6. Train Location

3.6.1. Description of the parameter

This parameter specifies the tracing possibility to get information about train location, train delays and performance. The information is based mainly on the stored message exchange from the IMs.

3.6.2. Characteristics to be respected

Access possibility

The access to this information must be independent from the communication relation RU / IM during the train running, which means that the RU must have a single access address to this information.

Accessible information

Train Running

Information on the last recorded status (location, delays and delay reasons) of one specific train on the infrastructure of a specified IM.

Train Delay / Performance

Information on all the delays to a specific train with a particular IM

Train Identifier

Information about the current Train ID and its previous Train Ids. Any of the Train Ids for a specific train can be used as access key to this information.

Train Forecast

Information about the forecast time for a specified train at a particular reporting location.

Trains at reporting Location

Information about all trains of an RU at a particular reporting location on the infrastructure of a specific IM.

3.7. Shipment ETI / ETA

3.7.1. Description of the parameter

This parameter describes the ETI /ETA calculation procedure and the needed message exchange between the RUs and the Lead RU.

ETI

Estimated Time of Interchange of a shipment (wagon) from one RU to the next RU in the transport chain.

ETA

Estimated Time of Arrival of a shipment (Wagon) on the consignee sidings.

RU's capability

Each RU must have the capability to receive and generate the ETI for the next RU

3.7.2. Characteristics to be respected

Open Access

In the case of Open Access, only one RU exists. This RU has to calculate the shipment related ETA for its customer after having established the trip plan for the shipment and it has to update the ETA each time, when a deviation during the transportation was detected.

Co-operation mode

In the co-operation mode the Lead RU sends the shipment / wagon order and the release time for the shipment / wagon to the first RU, which creates ETI and sends it to the next RU involved. The last RU creates the ETA and sends it back to the Lead RU. This procedure must be repeated when ever a deviation in the transportation of the shipment is detected or on request from the LRU. The needed message is the

- Wagon ETI / ETA message

Basis for the ETI / ETA calculation

The first calculation is based on the release time of the shipment / wagon. The updates are based on the information from the Infrastructure manager in charge, which sends, within the Train Running Forecast message for the train on which the shipment / wagon is transported, the Train Estimated Time of Arrival (TETA) for defined reporting points.

Intermodal units

For the intermodal units on a wagon, the wagon ETIs are also ETIs for the intermodal units, the wagon ETA must be calculated as ETIs for the intermodal units on the wagon by the last RU, since the RU delivers the wagon only to the intermodal terminal operator and not to the final customer.

Alert management

The Lead RU is responsible for the comparison with the commitment to the customer. Deviations of the ETA against the commitment to the customer must be handled in accordance with the contract and may lead to an Alert management process by the LRU. For the transmission of information on the result of this process an

- Alert message

is foreseen.

As a basis for the Alert management process, the LRU must have the possibility for a wagon related enquiry on deviations, done with Enquiry:

- Information about wagon deviation

3.8. Wagon Movement

3.8.1. Description of the parameter

This parameter describes the reporting of the movement of a wagon and defines the needed message exchange between RUs and Lead RU (acting as service integrator).

3.8.2. Characteristics to be respected

Open Access

In the case of Open Access only one RU exists, which also is the LRU. No data exchange to other RUs is needed. Therefore the wagon movement is an RU (LRU) internal process. The LRU itself is responsible for the data storage and updating of the wagon related movement database. The events which must be stored are:

- Wagon ready to be pulled from customer sidings
- Wagon pulled from customer sidings
- Wagon arrived at RU's yard
- Wagon has left the yard
- Any wagon exceptions
- Wagon arrived at destination yard
- Wagon placed on customer sidings

Co-operation model

For the reporting of the movement of a wagon, each RU involved must store the relevant data and must make it electronically accessible. The data must be also exchanged within message on contractual base to authorised parties.

Needed messages

Wagon Release notice

The Lead RU must tell the RU in charge that the wagon is ready for pull at the customer sidings at the given release time. This event must be stored in the wagon movement database.

Wagon Departure notice

The RU must inform the LRU of the actual Date and Time that the wagon has been pulled from the place of departure. This event must be stored in the wagon movement database.

Wagon Yard arrival

The RU must inform the LRU, that the wagon has arrived at its yard. This message can be based on a “Train running advice”. This event must be stored in the wagon movement database.

Wagon Yard departure

The RU must inform the LRU, that the wagon has left its yard. This message can be based on a “Train running advice” message. This event must be stored in the wagon movement database.

Wagon Exceptions message

The RU must inform the LRU about deviations e.g. bad order, including a new ETI / ETA. This information must be stored in the wagon movement database.

Wagon Arrival notice

The last RU in a wagon or Intermodal unit transport chain must inform the LRU that the wagon has arrived at its yard (RU location).

Wagon Delivery notice

The last RU in a wagon transport chain must inform the LRU that the wagon has been placed at the consignee’s sidings.

3.9. Interchange Reporting

3.9.1. Description of the parameter

The Interchange reporting describes the messages attached to the transfer of responsibility for a wagon between two Railway Undertakings, which occurs at interchange points. It also commands the new RU to make an ETI calculation.

3.9.2. Characteristics to be respected

Open Access

Nothing has to be specified, as there is always the same responsible RU during the complete transport chain. But from the Running Advice of the train at a reporting point, the wagon or Intermodal unit related information regarding location and Date and Time of arrival and departure must be processed and stored in the wagon movement database.

Co-operation mode

The following messages are needed to transfer the control and responsibility of a shipment from one RU to another, the information of which must be stored in the wagon movement database.

Wagon Interchange Notice

With the “Wagon Interchange Notice” a Railway Undertaking (RU 1) asks the next Railway Undertaking (RU 2) in the transport chain whether it accepts the responsibility for a wagon.

Wagon Interchange Notice / Subset

With the “wagon interchange notice / subset” the RU 1 informs the IM, that it is handling over the responsibility to the next RU.

Wagon Received At Interchange

With the “Wagon Received At Interchange” message, the RU 2 informs RU 1 that it accepts the responsibility for the wagon.

Wagon Refused At Interchange

With the “Wagon Refused At Interchange” message, the RU 2 informs RU 1 that it is not willing to take over the responsibility for the wagon.

3.10. Data Exchange for Quality Improvement

3.10.1. Description of the parameter

A measurement process is an essential post trip process to support quality improvements. In addition to measuring the service delivered to the customer, LRUs, RUs and IMs must measure the quality of the service components that in total make up the product delivered to the customer.

To measure quality the already defined messages can be used. The measurement process is a repetitive one.

3.10.2. Characteristics to be respected

Quality measurements LRU / Customer

In contracts between Lead RUs and Customers commitments can be made (depending on the individual agreement) regarding Transit time and ETA.

Quality measurements LRU / RUs

In contracts between a Lead RU and other RUs commitments can be made concerning transit times, ETIs, ETAs and Reason Codes.

Quality measurements RU / IM

In contracts between RUs and IMs, train schedules and target on time levels at specified timing points can be specified as can the accuracy of Train ETAs and ETHs.

Quality measurements RU / IM

In contracts between RUs and IMs path availability to run trains will be clearly described in terms of a range of times at specified points. Train specifications in terms of maximum length and gross weight, loading gauge etc., will also be covered in these contracts, which aspect will be addressed under item number 6.

The procedures and time frames for confirming the utilisation of a path, cancelling the use of a planned path and the extent to which a path can be used outside (early or late) the specified range of times will also be covered in these contracts.

Quality measurements RU / IM, Path Availability on short notice

Periodically the RU will compare the path request and the response data for producing reports as follows:

- Path request response time against framework agreement;
- Number of paths supplied within x, y, and z hours etc., of requested time;
- Number of rejected path requests.

Quality measurements IM / RU, Train composition quality

When the train ready messages and / or train composition lists are sent by an RU to the IM(s) (or to other RUs), they should comply with the train specifications contained within the applicable contract.

3.11. Various Reference Files

3.11.1. Description of the parameter

This parameter defines which additional references files must be available for the operation of freight trains in the European network.

3.11.2. Characteristics to be respected

Reference files

List of reference files

- Reference File of the numerical Coding for all IMs, RUs, and Service provider companies
- Reference File of the numerical Coding for Transport Customers
- Reference File of the Numerical Coding of Locations (Primary, subsidiary and zone-track-spot)
- Reference File of the numerical Coding for customer locations
- Reference File of all existing train control systems
- Reference File of Hazardous goods, UN and RID numbers
- Reference File of all different locomotive types
- Reference File of all CN and HS codes for goods
- Reference File of the emergency services, correlated to type of hazardous goods
- Reference File of all European maintenance workshops
- Reference File of all European audit bodies
- Reference File of all European accredited operators

Accessibility

The Reference files must be accessible to all Service Providers (IMs, RUs, Logistic providers and Fleet managers).

Actuality

The data must represent the actual status at all times.

Other Databases

To allow for the tracking of train and wagon movements, the following temporary databases, updated at each relevant event in real time, may be installed:

Wagon and Intermodal unit Movement Database

The communication between the Lead RU and RUs in the co-operation mode is based on wagon and/or Intermodal unit numbers. Therefore an RU, which communicates with the IMs at train level, must break down this information into wagon and Intermodal unit related. This wagon and Intermodal unit related information may be stored in wagon and Intermodal unit specific movement databases. The information on train movement leads to new entries / updates in the wagon and Intermodal unit movement database for customer information. This database is set up at the latest when receiving the release time for the wagons or Intermodal unit from the customer. This release time is the first entry into the Wagon and Intermodal unit movement database.

Train Data base

The Infrastructure Manager train database corresponds to the Railway Undertaking wagon movement database. The main data entries are the train related data of the train composition message from the RU. All train events result in an update of this train related database. An alternative storage possibility for these data is the path database.

Wagon Trip Plan

Trains normally carry wagons from various Customers. For each wagon the Lead RU establishes and updates a trip plan which corresponds to the train path at train level. New train paths for a train - e.g. in case of service interruptions - lead to a re-trip for the wagons of the various customers. The creation time for the trip plan is the receipt of the consignment note from the customer.

3.12. Electronic Transmission of Documents

3.12.1. Description of the parameter

This parameter considers the managing of electronic transmission of train and shipment related documents where the current process needs physical documents e.g. customs documents.

3.12.2. Characteristics to be respected

The next paragraph presents the communication network to be used for data exchange. This network and the described security handling make it possible for any type of network transmission, such as email, file transfer (ftp, http), etc. The type to choose can then be decided upon by the parties involved in the information exchange, which means, that the electronic transmission of documents, for example via ftp, is given.

3.13. Networking & Communication

3.13.1. Description of the parameter

This parameter describes the cost effective and timely networking and communication requirements for all the basic parameter messages in this TSI.

3.13.2. Characteristics to be respected

General Architecture

The Network & Communication infrastructure supporting such rail interoperability community will be based on a common **Information Exchange Architecture**, known and adopted by all participating actors.

The **Information Exchange Architecture**:

- is designed to reconcile heterogeneous information models by semantically transforming the data that is exchanged between the systems and by reconciling the business process and application-level protocol differences;
- has minimum impact on the existing IT architectures implemented by every actor;
- safeguards IT investments made already.

Scalability

The Information Exchange Architectures favours a mostly Peer-to-Peer type of interaction between all actors, while it guarantees the overall integrity and consistency of the rail interoperability community by providing a set of centralised services. A Peer-to-Peer interaction model allows the best cost distribution between the different actors, based on actual usage and will present, in general, lesser scalability problems.

Network

Networking in this case means the method and philosophy of communication and does not include the physical network.

The rail interoperability community is based on usage of the public Internet network, thus encouraging and lowering barriers for entry actors.

The security issue will therefore be addressed not by the network (VPN, tunnelling, ...), but by exchanging and managing inherently secure messages. A VPN network is therefore not required, thus avoiding problems with responsibilities and ownership allocation. Tunnelling is not considered as a necessary means for achieving the appropriate security level.

In any case if some actors already have or want to implement various degrees of security on selected partitions of the network, they can do so.

Over the public Internet network it is possible to implement a hybrid Peer to Peer model with a **central repository** and a **common interface** at each actors' node.

The central repository is approached first to obtain meta-information, such as the identity of the peer (actor) on which some information is stored, or to verify security credentials. Afterwards, a Peer to Peer communication is performed between involved actors.

Protocols

Only protocols belonging to the full Internet Protocol suite must be used.

Security

To achieve a high level of security, all messages must be self contained, which means that the information in the message is secured and the receiver can verify the authenticity of the message. This may be solved by using an encryption and signing scheme similar to email encryption. This makes it possible to use any type of network transmission, like email, file transfer (ftp, http), etc. The actual type to choose can then be decided upon by the parties involved in the information exchange.

Encryption

Either asymmetric encryption or a hybrid solution based on symmetric encryption with public key protection must be used, due to the fact that sharing a common secret key among many actors will fail at some point. A higher level of security is easier to achieve if every actor takes responsibility for its own pair of keys, even though the demand for a high level of integrity of a central repository (the key server) is required.

Central Repository

The Central Repository must be able to handle:

- metadata – structured data describing the content of messages;
- Public Key Infrastructure (PKI) ;
- Certification Authority (CA) ;
- directory (“phonebook”) – it contains all needed information about the participating actors for exchanging messages.

The management of the central repository should be under the responsibility of a non-commercial co-European organisation.

Common Interface

The Common Interface is mandatory for each actor in order to join the rail interoperability community.

The Common Interface has to be able to handle:

- message formatting of outgoing messages according to the metadata
- signing and encryption of outgoing messages
- addressing of the outgoing messages
- authenticity verification of the incoming messages
- decryption of incoming messages
- conformity checks of incoming messages according to metadata

Based on the results of authenticity verification of incoming messages, a minimum level of message acknowledgement can be implemented:

- i. positive send ACK
- ii. negative send NACK.

The common interface uses the information in the central repository in order to manage the above tasks.

An actor may implement a local “mirror” of the central repository to shorten response times.