



| | |
|---|---------------------|
| European Railway Agency | |
| GUIDE FOR THE APPLICATION OF THE ENE TSI | |
| According to Framework Mandate C(2010)2576 final of 29/04/2010 | |
| Reference in ERA: | ERA/GUI/07-2011/INT |
| Version in ERA: | 2.00 |
| Date: | 16 October 2014 |

| | |
|-------------------------------|---|
| Document elaborated by | European Railway Agency Rue Marc Lefrancq, 120 BP 20392 F-59307 Valenciennes Cedex France |
| Document Type: | Guide |
| Document Status: | Public |



0. DOCUMENT INFORMATION

0.1. Amendment record

Table 1: Status of the document

| Version Date | Author(s) | Section number | Modification description |
|-----------------------------------|-----------|----------------|---|
| Guide Version 1.00 26 Aug 2011 | ERA IU | All | First publication |
| Guide Version 2.00 16 Oct 2014 | ERA IU | All | Second publication following the revision of the (existing) ENE TSIs in force (merged and extended scope) |

0.2. Table of contents

| | |
|---|----------|
| 0. DOCUMENT INFORMATION..... | 2 |
| 0.1. Amendment record..... | 2 |
| 0.2. Table of contents..... | 3 |
| 0.3. List of tables | 3 |
| 1. SCOPE OF THIS GUIDE | 4 |
| 1.1. Scope | 4 |
| 1.2. Content of the guide..... | 4 |
| 1.3. Reference documents | 4 |
| 1.4. Definitions, abbreviations and acronyms | 4 |
| 2. GUIDANCE ON THE APPLICATION OF THE ENE TSI..... | 5 |
| 2.1 Foreword | 5 |
| 2.2 Essential requirements..... | 5 |
| 2.3 Characteristics of the subsystem | 5 |
| 2.4 Interfaces..... | 13 |
| 2.5 Interoperability constituents (ICs) | 16 |
| 2.6 Conformity assessment..... | 16 |
| 2.7 Implementation..... | 21 |

0.3. List of tables

| | |
|--|----------|
| <i>Table 1: Status of the document</i> | 2 |
|--|----------|

1. SCOPE OF THIS GUIDE

1.1. Scope

1.1.1 This document is an Annex to the “Guide for the Application of TSIs”. It provides information on the application of Technical Specification for Interoperability for the “energy subsystem” adopted by the Commission Regulation (Commission Regulation 1301/2014 (EU) (from now on referred as ENE TSI).

1.1.2 The guide needs to be read and used only in conjunction with the ENE TSI. It is intended to facilitate its application but it does not substitute for it.
The general part of the “Guide for the Application of TSIs” has also to be considered.

1.2. Content of the guide

1.2.1. In chapter 2 of this document, extracts of the original text of the ENE TSI are provided, shown in a shaded text box and these are followed by a text that gives guidance.

1.2.2 Guidance is not provided for every clause where the original ENE TSI requires no further explanation.

1.2.3 Guidance is of voluntary application. It does not mandate any requirement in addition to those set out in the ENE TSI.

1.3. Reference documents

Reference documents are indicated as a footnote in Commission Regulation and in its annexes (TSI ENE), and in the general part of the “Guide for the Application of TSIs”.

1.4. Definitions, abbreviations and acronyms

Definitions, abbreviations and acronyms are given in Appendix G of the ENE TSI, and in the general part of the “Guide for the Application of TSIs”.

2. GUIDANCE ON THE APPLICATION OF THE ENE TSI

2.1 Foreword

The geographical scope of the ENE TSI is the network of the whole Union rail system, as defined in article 2 of the Regulation.

As a general comment, it must be emphasised that TSI should not be considered as a design manual. Neither is it a complete list of assessments which should be done to start the operation of the subsystem. The process of putting in service any fixed installations is a subject to national construction law and commissioning processes which cover all elements including those not in the scope of the TSI.

The requirements set out in the TSI include only those elements which are important from the interoperability point of view, for the compatibility of the energy subsystem (as defined in the interoperability directive) with a TSI-compliant rail vehicle.

On existing lines, it is intended that as work is done, it will move towards achieving full compliance with the ENE TSI. This work can be done element by element over an extended period as stated in clause 7.3.2(1).

2.2 Essential requirements

The essential requirements cover:

- safety,
- reliability and availability,
- health,
- environmental protection,
- technical compatibility,
- accessibility

and are addressed in chapter 3 of the TSI.

2.3 Characteristics of the subsystem

The following clauses refer to respective points of the TSI.

2.3.1 Voltage and frequency (point 4.2.3)

(1) The voltage and frequency of the energy subsystem shall be one of the four systems, specified in accordance with section 7:

- AC 25 kV, 50 Hz;
- AC 15 kV, 16.7 Hz;
- DC 3 kV, or
- DC 1.5 kV

(2) The values and limits of the voltage and frequency shall comply with EN50163:2004, clause 4 for the selected system.

The wide extent of existing traction current supply systems and the fact that vehicles designed for operation on more than one traction system are the current state of the art, make the migration to one system not economically viable.

Therefore the application of AC 25 kV, 50 Hz; AC 15 kV, 16.7 Hz; DC 3 kV or DC 1.5 kV is permitted for new, upgraded or renewed subsystems taking into account the provisions set out in section 7 of the TSI (see also 2.7.2 of this guide).

The voltage and frequency parameters for these systems are standardised in EN 50163:2004.

On lines with a speed higher than 250 km/h, only AC systems are permitted because of the high power demand of trains (point 7.2.2. Migration strategy for voltage and frequency of ENE TSI).

For information about the implementation of this TSI see 2.7 of this guide.

2.3.2 Parameters relating to supply system performance (point 4.2.4)

- *Maximum train current*

The energy subsystem design shall ensure the ability of the power supply to achieve the specified performance and allow the operation of trains with a power less than 2 MW without power or current limitation.

To avoid unnecessary rolling stock costs it was decided that the energy subsystem should allow scheduled trains (a combination of rolling stock coupled together) up to 2 MW without power or current limitations.

Power or current limitation should be understood according to clause 7.3 (Power or current limitation device) of EN 50388:2012.

This power limit refers to the maximum power taken from the OCL for a complete train.

The limitations in EN 50388:2012 chapter 7.2 (Automatic regulation) apply to all trains regardless of installed power.

An interface with Operation and traffic management subsystem (Train composition and preparation of the Route Book) has been introduced to complete the scope of this parameter (see also 2.4.2 of this guide).

The maximum allowed train current is given in the RINF, clause 1.1.1.2.2.2.

- *Mean useful voltage*

The calculated mean useful voltage “at the pantograph” shall comply with EN 50388:2012, clause 8, (except clause 8.3 that is replaced by point C.1 of Appendix C).

Simulation shall take into account values of the real power factor of trains.

Point C.2 of Appendix C provides additional information to clause 8.2 of the EN 50388:2012.

Mean useful voltage as a quality index for the power supply system is the only proposed index in EN 50388:2012 for sizing the energy system. This parameter is calculated according to EN 50388:2012, clause 8 (Requirements for performance of power supply). To complement it, Appendix C was added to give more details of the calculation method.

When calculating the power supply quality it is important to remember that the objective is a power supply system that in normal operation it can supply every train with the power required in order to meet the timetable within reasonable costs.

2.3.3 Current capacity, DC systems, trains at standstill (point 4.2.5)

The OCL of DC systems shall be designed to sustain 300 A (for a 1.5 kV supply system) and 200 A (for a 3 kV supply system), per pantograph when the train is at standstill.

The current capacity at standstill shall be achieved for the test value of static contact force given in table 4 of clause 7.2 of EN 50367:2012.

The OCL shall be designed taking into account the temperature limits in accordance with EN 50119:2009 clause 5.1.2.

The purpose of this requirement is to prevent overheating of the pantograph contact strip / contact wire contact point when the train is at standstill and is drawing power, for example for auxiliary equipment.

Information on which contact strip material is used for the tests has to be indicated in the technical file.

2.3.4 Regenerative braking (point 4.2.6)

AC power supply systems shall be designed to allow the use of regenerative braking able to exchange power seamlessly either with other trains or by any other means.

DC power supply systems shall be designed to permit the use of regenerative braking at least by exchanging power with other trains.

Regenerative braking for both AC and DC systems is widely used in modern rolling stock.

Current technologies, during regenerative braking, allow injection of current into the system with a low harmonic content, which reduces the impact on the quality of energy delivered by the energy supplier to other consumers.

The phrase: “by any other means” covers feeding back energy in the public grid, storage or direct use of energy for other purposes or other consumers.

2.3.5 Electrical protection coordination arrangements (point 4.2.7)

Electrical protection coordination design of the energy subsystem shall comply with the requirements detailed in EN 50388:2012, clause 11.

To co-ordinate protection, a global view of the whole process and the interfaces between the subsystems LOC&PAS and energy is necessary.

For this, the ENE TSI refers to clause 11 (Coordination of protection) of EN 50388:2012.

It is important to note that although clause 11 of the EN 50388:2012 describes the complete electrical protection coordination arrangements, in the ENE TSI only the requirements for the substations are mandatory.

2.3.6 Harmonic and dynamic effects for AC systems (point 4.2.8)

The interaction of traction power supply system and rolling stock can lead to electrical instabilities in the system.

In order to achieve electrical system compatibility, harmonic overvoltages shall be limited below critical values according to EN 50388:2012 clause 10.4.

These phenomena are related to the harmonic and dynamic characteristics of power supply fixed installations and rolling stock, which can create overvoltages and other instability phenomena in the power supply system.

Particular attention should be paid when introducing a new element (see EN 50388:2012 clause 10.2 (Acceptance procedure for new elements)) into an existing, stable electric environment. The TSI stresses the need for a compatibility study to be carried out in this case, to assess any consequences resulting from the introduction of the new element into the system. The compatibility study is explained in detail in EN 50388:2012 clause 10 (Harmonics and dynamic effects), to which the TSI makes a reference.

The role of the notified body on this issue is only to check if criteria of EN 50388:2012 clause 10.4 (Methodology and acceptance criteria) are fulfilled in the presented study.

2.3.7 Geometry of the overhead contact line (point 4.2.9)

The overhead contact line shall be designed for pantographs with the head geometry specified in the LOC&PAS TSI point 4.2.8.2.9.2 taking into account the rules set out in point 7.2.3 of this TSI.

- *Contact wire height*

Geometry of the overhead contact line is the main interface with the pantograph.

The contact wire height is defined by table 4.2.9.1, including the nominal contact wire height, the minimum design contact wire height and the maximum design contact wire height.

These three values are in relation with the design speed of the line.

Additional information on the minimum and maximum design contact wire heights is given in EN 50119:2009.

These values are given in the RINF, clauses 1.1.1.2.2.5 and 1.1.1.2.2.6.

Those parameters are set out to ensure that the absolute minimum and maximum values are always within the pantograph working range.

Maximum contact wire height is included to fulfil local needs (e.g. washing tracks, workshops, loading areas, etc.) where trains move at low speed, without requirements regarding dynamic behaviour and quality of current collection performance between the pantograph and the OCL.

The contact wire gradient and rate of change of gradient is taken into account to assure proper dynamic behaviour and quality of current collection (4.2.12).

For the 1520 mm track gauge network, particular requirements for height have been included.

- *Maximum lateral deviation*

The maximum lateral deviation of the contact wire in relation to the track centre line under action of a cross wind shall be in accordance to table 4.2.9.2.

The values shall be adjusted taking into account the movement of the pantograph and track tolerances according to Appendix D.1.4.

The maximum permissible lateral deviation is related to the target profiles of the pantograph head, as defined in the LOC&PAS TSI, point 4.2.8.2.9.2.

Lateral deviation values are adapted in accordance with the pantograph movement and track tolerances taking into account Appendix D to the ENE TSI.

For the 1520 mm track gauge network, particular values for lateral deviation are set out.

2.3.8 Pantograph gauge (point 4.2.10)

Determination of the mechanical kinematic pantograph gauge.

This point – together with Appendix D to the ENE TSI – is based on the EN 15273 series relating to detailed calculation of gauge for infrastructure and vehicles.

This TSI uses the concepts of width and length of the pantograph head as defined in Figure 2.3.7 below.

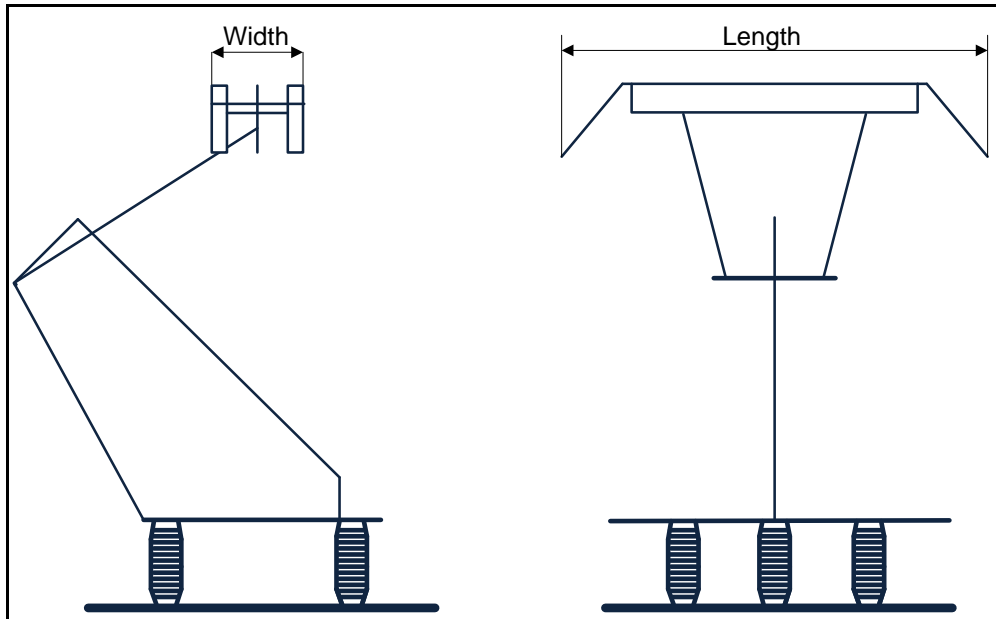

Figure 2.3.7 – Pantograph head, width and length (according to Fig. 1 EN 50206-1:2010)

Appendix D is considered to be more specific to TSI conforming rolling stock and pantographs.

Appendix D defines the reference profile that is used to calculate the minimum structure gauge necessary for free passage and the maximum lateral deviation of the contact wire.

Determination of the static pantograph gauge:

Appendix D contains the requirement for static pantograph gauge for the 1520 mm track gauge network.

2.3.9 Mean contact force (point 4.2.11)

- (1) The mean contact force F_m is the statistical mean value of the contact force. F_m is formed by the static, dynamic and aerodynamic components of the pantograph contact force.
- (2) The ranges of F_m for each of the power supply systems are defined in EN 50367:2012 Table 6.
- (3) The overhead contact lines shall be designed to be capable to sustain the upper design limit of F_m given in EN 50367:2012 Table 6.
- (4) The curves apply to speeds up to 320 [km/h]. For speeds above 320 [km/h] procedures set out in point 6.1.3 shall apply.

To define the contact force limits for interaction performance, a reference to the EN 50367:2012 replaces the former curve charts and formulas (see HS and CR TSI ENE - limits for interaction performance (contact force)).

The formulas in EN 50367:2012 (table 6) represent the upper design limit of F_m , following the same approach as in the CR ENE TSI.

Consequently OCL should be designed to accept a vehicle with a pantograph exerting a contact force in the range between $F_{m,min}$ and $F_{m,max}$ as indicated in EN 50367:2012 (Table 6).

TSI requires that the overhead contact line is designed to be capable to sustain the upper design limit of F_m given in EN 50367:2012 Table 6. Therefore, the mean contact force exerted during the measurement for the assessment of the OCL is $F_{m,max}$ or higher. This is necessary because of the fact that F_m cannot be adjusted exactly for the measurement.

2.3.10 Dynamic behaviour and quality of current collection (point 4.2.12)

(1) Depending on the assessment method, the overhead contact line shall achieve the values of dynamic performance and contact wire uplift (at the design speed) set out in Table 4.2.12.

Compared with previous TSIs, requirements for dynamic behaviour and quality of current collection have been separated from assessment methods.

For more details about assessment, see 2.6 of this guide.

2.3.11 Pantograph spacing (point 4.2.13)

The overhead contact line shall be designed for a minimum of two pantographs operating adjacently, in such a way that minimum spacing centre line to centre line of adjacent pantographs heads is equal or lower than values set out in one column "A", "B", or "C" selected from Table 4.2.13.

For the design of OCL, it is important to underline that the aim of the values in table 4.2.13 is:

- to set out that OCLs have to be designed to accept at least two pantographs.
- to set out a classification of OCL design configurations (types A, B or C).
- to set out the maximum distance from centre line to centre line of adjacent pantographs for OCL design.
- to set out a baseline for specifying the OCL limits in the RINF with which the operators need to take into account before placing a train into service on the line. When the operator does not comply with the values given in RINF, additional tests can be performed.
- not to set out the minimum distance from centre line to centre line of adjacent pantographs heads in the context of LOC&PAS IC or subsystem assessment.

Design values for AC-OCL of type B (ordinates: distance (m), abscissas: speed (km/h))

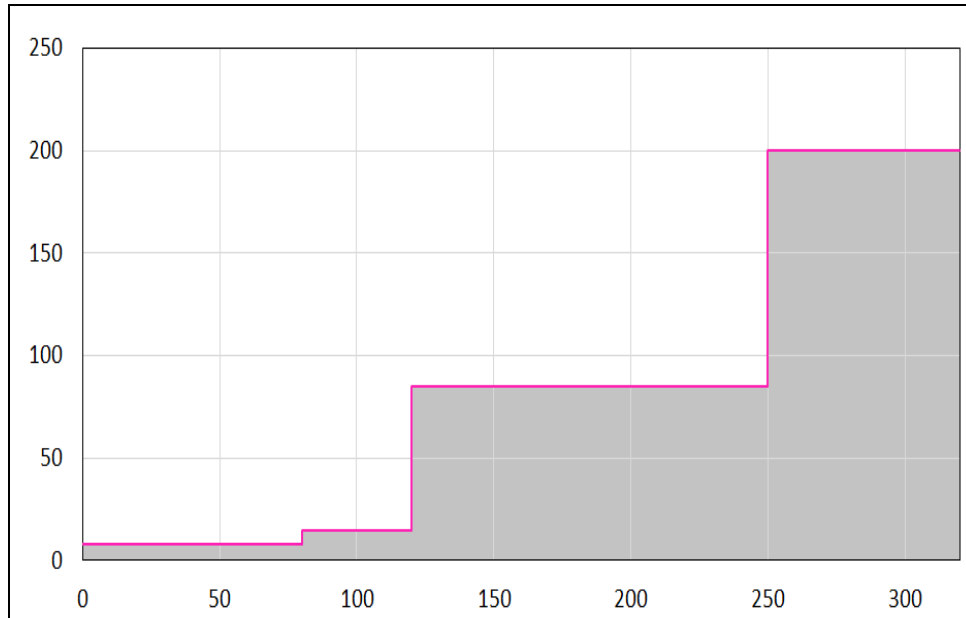

The figure above gives an example for an AC- OCL of type B. The OCL designer is free to move the boundary line further within the grey area. The actual values are given in the RINF. When the values are exactly the values of type B, then the white area gives the allowed values for trains.

Table 4.2.13 - *Pantograph spacing for OCL design* - defines the minimum spacing centre line to centre line of two pantographs operating adjacently.

The columns headed “A”, “B” and “C” are specified as a “benchmark” to define a minimum specification of the performance of the overhead line for the operation of trains with up to two pantographs. This “benchmark” sets an assessable position.

The actual design spacing can be reduced to allow the operation of trains with closer pantographs at a higher speed, or to allow for three or more pantographs in use on a train. In many cases, building to the minima defined by the TSI may be insufficient to deliver the needs of particular train operators – the designer needs to take this into account when designing the overhead line.

Information about the number of pantographs operating on a train and the distances between two consecutive pantographs which can be used on a certain line at a given speed are set in the RINF, clause 1.1.1.2.3.3.

2.3.12 Separation sections (point 4.2.15 and 4.2.16)

The main goal of the separation sections is to ensure that a vehicle passing through does not bridge two adjacent phases/systems.

In case of lines with speed $v \geq 250$ km /h the requirements from HS ENE TSI related to design were kept. For other lines the TSI gives greater freedom in the design of the separation sections.

Details of the particular separation section are given in the RINF, clause 1.1.1.2.4.

Further information is given in EN50367:2012 and EN50388:2012.

Where necessary to separate two feeding sections of the same system (phase shift occur without any load), the rules for phase separation sections are applicable as well.

Section length in separation sections has to ensure that overlaps between the sections are considered. The overall length D will ensure that the first passing pantograph will securely leave the first section before the second one enters into it. The definition of D within separation sections using static calculation is not sufficient, dynamic influence has to be taken into account.

2.3.13 On-ground energy data collecting system (point 4.2.17)

(2) The on-ground energy data collecting system shall receive, store and export CEBD without corrupting it.

The significant impact on drafting ENE TSI (compare to CR ENE TSI) had the extension by the new Directive 2011/18/EU (amending Directive 2008/57/EC), of the Energy subsystem to cover also the trackside of the electricity consumption measuring system.

The traction current measuring system has been split into two parts:

- On-ground energy data collecting system (DCS), set out in the ENE TSI,
- On-board energy measurement system (EMS), set out in the LOC&PAS TSI.

More details on the implementation strategy are in 2.7.4 of this guide.

There is no assessment of the on-ground energy data collecting system to be carried out by the notified body in the verification of the energy subsystem.

2.4 Interfaces

The interfaces between energy and other subsystems are covered in point 4.3 of the TSI. In this section only interfaces which need more explanations are developed.

Compared to the previous ENE TSIs the relevance with SRT TSI was removed, because the particular requirements related to the energy subsystem to be considered in tunnels are covered by the new SRT TSI.

2.4.1 Interface with Rolling Stock subsystem.

The complete list of corresponding parameters between ENE and LOC&PAS TSI are given in the table 4.3.2. In the points below particular aspects are highlighted.



2.4.1.1 Contact wire material / Contact strip material

The interface between rolling stock and energy subsystems and related parameters in both TSIs has taken into account the results of the research project (CoStrIM-contact strip material) in the case of acceptance of copper impregnated carbon on AC network. Other materials, approved on particular networks, are indicated in the RINF, clause 1.1.1.2.3.4.

2.4.1.2 On-ground energy data collecting system/on-board energy measurement system

Following the publication of the Directive 2011/18/EU, the introduction in the scope of energy subsystem the trackside of the electricity consumption measuring system, required a closer look at the interface between vehicle and ground in data transmission. While drafting ENE TSI there was not common agreement on this interface and as a result the specification related to interface protocols and transferred data format are an open point (see Appendix D of LOC&PAS TSI).

It is important to differentiate the meaning of the following concepts:

- Energy settlement system,
- Data collecting system.

Energy settlement system is defined as the process by which data from measured points are attributed to the particular point of the energy supply chain, combining with tariff information, providing a basis for payments for the volume of energy, the use of system charges associated with transmission and distribution networks, and also the contractual trade arrangement between the actors of the energy chain (e.g. generators, transmission / distribution system operators, suppliers, customers etc.).

Data collecting system is an on-ground service collecting the Compiled Energy Billing Data (CEBD) from an on-board energy measurement system (EMS).

Following diagram illustrates the main relationships:

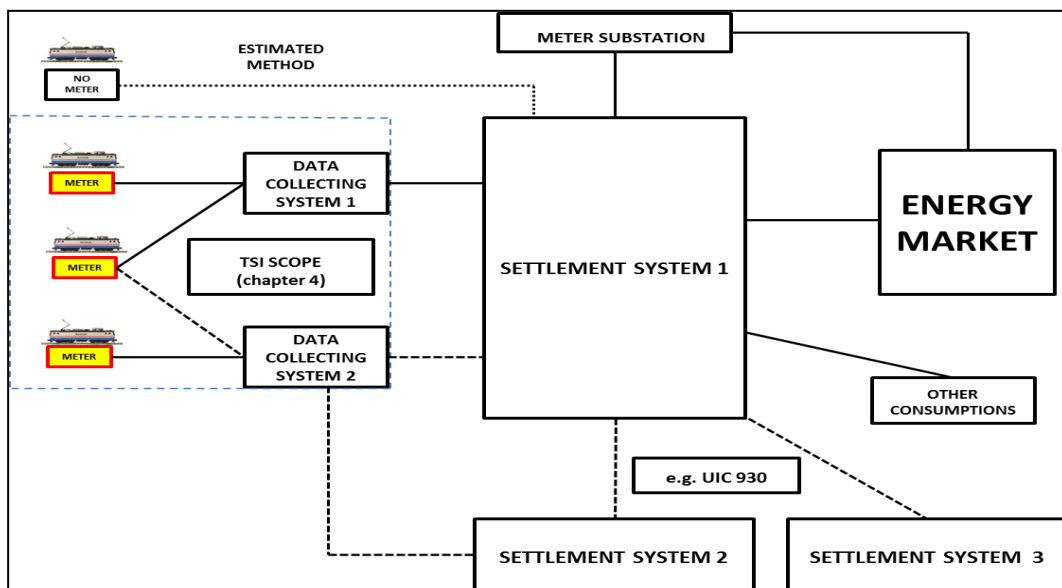

From the railway interoperability point of view, it is required for any EMS to be able to exchange data with any DCS.

The aim of UIC 930 (Exchange of data for cross-border railway energy settlement) is to define the processes and protocols used for exchange of energy consumption data between IMs, and therefore compliance with UIC 930 is not required by ENE TSI.

Member States shall ensure that an on-ground settlement system capable of receiving data from any DCS and accept it for billing is to be implemented, two years after the closing of the open point noted below.

Open point

The open point relates to the on-board to ground communication protocol and the structure and the format of the data (e.g. XML).

ENE TSI Regulation states that this open point shall be closed 2 years after the entry into force of this ENE TSI Regulation.

Appendix I of LOC&PAS TSI (Open points that do not relate to technical compatibility between the vehicle and the network) indicates that the EN 61375-series (Train communication network) of standard should be used.

The solution set out in Annex A of EN 50463-4 2012 (Energy measurement on board trains, Part 4: Communication) (containing protocol and data format) and defined as the preferred solution is intended to be broadly compatible with EN 61375.

The EN 50463:2012 series (Energy measurement on board trains) is being revised to define the format of the data and to ensure full compatibility with the EN 61375 series (Train communication network).

2.4.2 Operation and traffic management

The Energy subsystem not only interfaces with an individual unit (defined in the LOC&PAS TSI) but also with a train (which can be a composition of units assembled by the RU at the operational level). In this context there are some energy subsystem parameters (see point 4.3.5 of ENE TSI) which have an interface with the operation and traffic management subsystem. Those parameters having impact on the design of the energy subsystem, and affect the preparation and operation of trains are reflected in the Register of Infrastructure and RU documents (route book).

2.5 Interoperability constituents (ICs)

OCL as IC

Experience supports the idea of keeping OCL as IC, because the advantages are important:

- harmonisation of the different “types” of OCL,
- reduction of the proliferation of different versions of OCL and different assessment stages of the same OCL if applying the procedure of an intermediate statement of verification (ISV),
- OCL can be offered as a “product” on the market,
- reduction in the process of assessment of the subsystem when using an OCL that has already been certified.

Overhead contact line, see 5.1 (2) (b) of ENE TSI.

Regarding the definition of OCL, in point 5.1, feeders and jumpers are included in so far as they are influenced by parameters defined in point 5.2 of the ENE TSI.

2.6 Conformity assessment

2.6.1 General

The conformity assessment is performed on two levels:

- assessment of conformity of the interoperability constituent (the OCL), defined in point 6.1 of the ENE TSI,
- the EC verification of the energy subsystem, defined in point 6.2 of the ENE TSI.

For the assessment of conformity of the interoperability constituent OCL and EC verification of the energy subsystem modules defined in in the Commission Decision 2010/713/EU apply. The choice between modules, for the IC and subsystem is given in chapter 6 of the ENE TSI.

When a particular assessment procedure is needed, the ENE TSI describes it in specific sections (OCL is defined in 6.1.4 and subsystem defined in 6.2.4).

Some aspects of the particular assessment procedure are explained below.

2.6.2 Interoperability constituent – overhead contact line

The goal of the assessment procedure is to verify the design of the OCL against the relevant requirements set out in point 5.2.1 of the ENE TSI.

Table A.1 describes the assessment stages of the OCL as IC.

The assessment of the OCL as an IC is carried out in two phases; a design review, and for some parameters tests are required, in accordance with the particular assessment procedure for the interoperability constituent (see 6.1.4 of the ENE TSI).

Particular attention should be paid to the assessment of existing OCL designs used before the publication of this TSI (see point 2.6.4 of this guide).

2.6.2.1 Particular assessment procedure for the interoperability constituent – overhead contact line

2.6.2.1.1 Assessment of dynamic behaviour and quality of current collection

The dynamic behaviour and quality of current collection describes the relationship between the overhead contact line and pantograph in order to obtain the proper quality of current collection and to avoid excessive wear or damage.

To improve clarity, compared with the previous CR ENE TSI, this point has been rearranged into 3 parts:

- Methodology (containing general explanations)
- Simulation (design review)
- Measurement (site tests)

To facilitate and accelerate the process of assessment, the TSI includes the possibility of performing the simulation using types of pantograph that are under the process of IC certification, provided that they fulfil the other requirements of LOC&PAS TSI.

Assessment of this requirement is defined in point 6.1.4 of the ENE TSI and the performance is confirmed by simulation at each of the speed / pantograph spacing combination for which the overhead line has been designed. For EC certification of the OCL design as an IC, at least the worst case arrangements (spacing / speed) of pantographs derived from the simulation is repeated in a site dynamic test.

In site tests with multiple pantographs, a combination of the two pantographs that have been used in the simulation is permitted.

The procedure to assess the dynamic behaviour and current collection of the pantograph as IC is not in the scope of ENE TSI but is defined in LOC&PAS TSI.

2.6.2.1.2 Assessment of current at standstill (DC systems)

For DC systems, additional assessments need to be done to avoid overheating of the contact point at standstill.

The methodology is defined in Annex A.3 (additional tests for DC systems) of EN 50367:2012. For the assessment, the test value of static contact force given in EN 50367:2012 (table 4, point 7.2) should be used.

2.6.3. Energy subsystem

The main concerns in the assessment of energy subsystem refer to the incorporation of the OCL into it.

In general the energy subsystem must contain an OCL - IC which holds an EC declaration of conformity. In this case the assessment of the design of the OCL is already done and the assessment of the OCL in the subsystem will focus on the integration into subsystem.

If the energy subsystem consists of an OCL which does not hold an EC declaration of conformity (as specified in 6.3 of the ENE TSI), the assessment of the energy subsystem will take more effort. In this case the OCL also needs to be assessed against the requirements as defined in Table B of the ENE TSI (indicated by X²).

2.6.3.1 Particular assessment procedures for Energy Subsystem - related to OCL

When the OCL has been certified as an interoperability constituent, it can be used on interoperable lines after the integration into a subsystem.

2.6.3.1.1 Assessment of dynamic behaviour and quality of current collection (integration into a subsystem)

The main aspect of assessment of the dynamic behaviour and quality of current collection of a certified OCL is the identification of allocation design and installation errors.

These measurements shall be carried out with an interoperability constituent pantograph, exhibiting the mean contact force characteristics as required by point 4.2.11 of this TSI for the design speed of the line considering aspects related to minimum speed and siding tracks.

Minimum speed should be understood as the operational speed for any track. When the operational speed is less than the design speed of the IC OCL (e.g. for layout and/or track and/or signalling constraints), the test should be carried out at the maximum operational speed of the track.

The maximum operational speed of the track is included in the 'EC' certificate of verification issued by the notified body in the conditions of validity of the certificate.

For speeds up to 120 km/h (AC systems) and for speeds up to 160 km/h (DC systems) significant installation errors are not generally demonstrated by contact force measurement. In this case, alternative methods of identifying construction errors may be used, such as measurement of the contact wire height, stagger and space for uplift. This approach cannot be adopted for the process of IC certification.

2.6.4. Assessment of existing OCL designs - clarifications

The implementation of ENE TSI for the existing OCL designs creates concerns and questions in relation to the process of assessment, which can be summed up in three groups:

- a) Legal framework for further application of existing OCL designs which are already in use in the particular network (for OCL as IC and for non-certified OCL)

At the beginning it has to be underlined that ENE TSIs did not set any new requirements and generally reflected the current state of the art. In this sense the existing OCLs in use, supported by extensive operational and maintenance records, should fulfil most of the TSI requirements.

For existing OCLs being a subject to conformity assessment the process is performed according to point 6.1.2 of ENE TSI. In this point, for an IC placed on the EU market before entry in force of this TSI, the application of following modules are foreseen: CA – internal production control (without involvement of notified body) or CH – conformity based on full quality management system (with involvement of notified body checking the quality management system of an applicant).

For non-certified OCL integrated into ENE subsystem the process described in point 6.3 of ENE TSI can be used, but with limited period of time.

This gives the option of using existing OCL – generally inside the given network – with proven experience (operational and maintenance records).

It is particularly important for upgrading and renewals when the project is in constant development during a period of time on the operational line or extension of existing network. In this case, experiences gained from the fulfilment of ENE TSI subsystem requirements (chapter 4) should be enough for placing in service the subsystem. It is the responsibility of the applicant to decide whether to also check this OCL against the assessment procedure(s) of point 6.1 of the ENE TSI.

Though an OCL-IC can be offered on other ‘markets’ as a ‘product’ but it should be noted that it is a ‘particular product’ which exists as a design and as a real assembly only when it is incorporated into a subsystem.

To cover the risk related to special features (e.g. tunnels, bridges, layout, etc.) when the OCL-IC is integrated into a new subsystem, it is optional for the applicant to decide whether to check also this OCL against the assessment procedure(s) of point 6.1 of the ENE TSI.

- b) Performing the process of IC certification if simulations tools, data for simulations etc. are not available.

This issue was raised when application the CR ENE TSI was undertaken and it refers only to the assessment of the parameter of dynamic behaviour and quality of current collection. In the detailed methodology described in the CR ENE TSI the approach of revised HS ENE TSI was followed with the focus on:

- Use of simulations to reduce the number of site tests, and
- Site measurement tests with the chosen pantograph and section of the line.

After feedback from the implementation of TSIs some concerns were raised:

- Access to simulation tools, developed particularly for the extensions to the HS network. They are often tailor made, dedicated computer programs and constantly being improved based on return of experience.
- Availability of the data – mathematical models of pantographs and OCL types (which may be a subject of propriety laws).

It should be underlined that these problems are temporal and depend on the limited number of certified ICs available on the market. The issue will be resolved by the increase number of new products, wider implementations of TSIs, and updated databases (like ERADIS).

CENELEC is also now revising (new work item in 2014) the existing standard EN 50318 (Validation of simulation of the dynamic interaction between pantograph and overhead contact line) to incorporate mathematical models of OCL and pantographs to help in development and application of simulating tools.

The close cooperation between infrastructure manager and vehicles manufacturer (or RU) will speed up the assessment process for benefits of both.

In case of existing OCL designs in operation for at least 20 years, to facilitate the assessment of the energy subsystem and to open the market, in the TSI a provision has been introduced reducing the assessment to only the measurement.

- c) Need for dynamic tests in the case of integration into subsystem OCL types for speeds applied in the conventional network.

The issue has been addressed in the point above (see 2.6.3). As it was underlined in the TSI, the main idea behind these tests is the identification of allocation design and installation errors, taking into account that the OCL was entirely checked under the process of IC certification.

Following this approach and with benefit of experience and with the aim of reduction in the number of tests (and related costs) for speeds given in the TSI (see point 6.2.4.5 (5) of the ENE TSI) the dynamic contact force measurement is considered unnecessary for the identification of significant installation errors. In this case static measurements are deemed sufficient for this purpose.

2.6.5. Assessment of protective provisions against electric shock (4.2.18)

The notified body should assess the stages of the production phase indicated in Table B.1 only if no other independent body has done so.

An 'independent body' means in this context any assessment entity (body or person) which is competent according to national legislation (such as construction law or railway law) to perform an assessment of the protective provisions against electric shock.

This independent body may be or not an organisation which is also acting as a notified body or designated body within the meaning of Interoperability Directive 2008/57 EC.

To avoid unnecessary the repetition of these tests, the applicant for EC verification in accordance with the ENE TSI should inform the notified body the existence of these tests and provide the relevant certificates and technical documentation.

The notified body should include evidence of the independent body checks in the technical file, and indicate it in the EC certificate.

2.6.6 Additional clarification of Table B.1 - EC verification of the energy subsystem

For the correct interpretation of the table B.1, for the following parameters, the indication N/A should be understood as that the assessment is generally not performed by NoBo except the situations given below:

- Geometry of the overhead contact line (4.2.9), in the column Assembled, before putting into service, when an alternative assessment method is used as foreseen in point 6.2.4.5. (Assessment of dynamic behaviour and quality of current collection (integration into a subsystem) of the TSI and,
- Dynamic behaviour and quality of current collection (4.2.12), in the column Validation under full operating conditions, when the validation in the phase "Assembly before putting into service" is not possible due to e.g.: operationally limitation of the maximum speed or load need for the stability of the track.

2.7 Implementation

2.7.1 General

In the energy subsystem, the two most important items to achieve free access are:

- the power supply system, and
- the overhead contact line which allows passage of the target pantographs.

In addition, special attention should also be given to the implementation of 'the trackside of the electricity consumption measuring system' as one of the parts of the energy subsystem.

2.7.2 Implementation plan for voltage and frequency (point 7.2.2)

The issue of supply system should be considered with flexibility, taking account of the local situation and other subsystems such as the Control-Command and Signalling (CCS) or Infrastructure and progress in multisystem vehicle technologies.

The decision relating to the supply system should be taken at Member State level, because it entails not only commitments in the railway sector but also in others, including the necessary investments in the energy (transmission/distribution) system, regional development and international agreements.

In case of high speed lines – for new lines with speed greater than 250 km/h the choice is limited to AC systems taking into account the power demand and reduction of losses in the fixed installations.

2.7.3 Implementation plan for OCL geometry (point 7.2.3)

The strategy for the Member State, OCL geometry should include the entire network for the Member State, taking into account the network as a system with potential areas and corridors that may need different strategies. Strategies for neighbouring areas and corridors will also need to be considered.

The implementation plan states the following rules:

- (a) New lines with speed greater than 250 km/h shall accommodate both pantographs length (1600 mm + 1950 mm as defined in the LOC&PAS TSI points 4.2.8.2.9.2.1 and 4.2.8.2.9.2.2). If this is not possible, the OCL shall be designed for use by at least the 1600 mm pantograph.
- (b) Renewed or upgraded lines with speed equal or greater than 250 km/h shall accommodate at least the 1600 mm pantograph.
- (c) Other cases: the OCL shall be designed for use by at least one of the pantographs: 1600 mm pantograph or 1950 mm pantograph.

For track gauge systems other than 1435mm, the OCL shall be designed for use by at least one of the following pantographs:

- 1600 mm pantograph
- 1950 mm pantograph
- 2000/2260 mm pantograph (specified in the LOC&PAS TSI point 4.2.8.2.9.2.3).

2.7.4 Implementation of the on-ground energy data collecting system (point 7.2.4)

The process of implementation of the on-ground energy data collecting system is complex and involves actors outside the railway sector. It should be done with a close cooperation of the energy and railway market regulators. It should be underlined that it refers not only to the adaptation of technical solutions but it may also influence the current national legal framework related to implementation of energy market directives, railway directives and other national legislations (such as - fiscal). It is also important to define the role and



responsibilities of railway entities (IMs, RUs) in the energy market. The TSI imposes a tight schedule – within 2 years after closing the ‘open point’ in 4.2.17 for this task.